



Submersible Motors

Application ♦ Installation ♦ Maintenance

60 Hz, Single and Three Phase Motors

August 2000 Edition



Franklin Electric

The Company You Trust Deep Down

ATTENTION!
IMPORTANT INFORMATION FOR INSTALLERS OF THIS EQUIPMENT!

THIS EQUIPMENT IS INTENDED FOR INSTALLATION BY TECHNICALLY QUALIFIED PERSONNEL. FAILURE TO INSTALL IT IN COMPLIANCE WITH NATIONAL AND LOCAL ELECTRICAL CODES, AND WITH FRANKLIN ELECTRIC RECOMMENDATIONS, MAY RESULT IN ELECTRICAL SHOCK OR FIRE HAZARD, UNSATISFACTORY PERFORMANCE, AND EQUIPMENT FAILURE. FRANKLIN INSTALLATION INFORMATION IS AVAILABLE FROM PUMP MANUFACTURERS AND DISTRIBUTORS, AND DIRECTLY FROM FRANKLIN ELECTRIC. CALL FRANKLIN TOLL FREE 800-348-2420 FOR INFORMATION.

WARNING

SERIOUS OR FATAL ELECTRICAL SHOCK MAY RESULT FROM FAILURE TO CONNECT THE MOTOR, CONTROL ENCLOSURES, METAL PLUMBING, AND ALL OTHER METAL NEAR THE MOTOR OR CABLE, TO THE POWER SUPPLY GROUND TERMINAL USING WIRE NO SMALLER THAN MOTOR CABLE WIRES. TO REDUCE RISK OF ELECTRICAL SHOCK, DISCONNECT POWER BEFORE WORKING ON OR AROUND THE WATER SYSTEM. DO NOT USE MOTOR IN SWIMMING AREAS.

ATTENTION!
INFORMATIONS IMPORTANTES POUR L'INSTALLATEUR DE CET EQUIPEMENT.

CET EQUIPEMENT DOIT ETRE INTALLE PAR UN TECHNICIEN QUALIFIE. SI L'INSTALLATION N'EST PAS CONFORME AUX LOIS NATIONALES OU LOCALES AINSI QU'AUX RECOMMANDATIONS DE FRANKLIN ELECTRIC, UN CHOC ELECTRIQUE, LE FEU, UNE PERFORMANCE NON ACCEPTABLE, VOIRE MEME LE NON-FONCTIONNEMENT PEUVENT SURVENIR. UN GUIDE D'INSTALLATION DE FRANKLIN ELECTRIC EST DISPONIBLE CHEZ LES MANUFACTURIERS DE POMPES, LES DISTRIBUTEURS, OU DIRECTEMENT CHEZ FRANKLIN. POUR DE PLUS AMPLES RENSEIGNEMENTS, APPELEZ SANS FRAIS LE 800-348-2420.

AVERTISSEMENT

UN CHOC ELECTRIQUE SERIEUX OU MEME MORTEL EST POSSIBLE, SI L'ON NEGLIGE DE CONNECTER LE MOTEUR, LA PLOMBERIE METALLIQUE, BOITES DE CONTROLE ET TOUT METAL PROCHE DU MOTEUR A UN CABLE ALLANT VERS UNE ALIMENTATION D'ENERGIE AVEC BORNE DE MISE A LA TERRE UTILISANT AU MOINS LE MEME CALIBRE QUE LES FILS DU MOTEUR. POUR REDUIRE LE RISQUE DE CHOC ELECTRIQUE. COUPER LE COURANT AVANT DE TRAVAILLER PRES OU SUR LE SYSTEM D'EAU. NE PAS UTILISER CE MOTEUR DANS UNE ZONE DE BAIGNADE.

ATENCION!
INFORMACION PARA EL INSTALADOR DE ESTE EQUIPO.

PARA LA INSTALACION DE ESTE EQUIPO, SE REQUIERE DE PERSONAL TECNICO CALIFICADO. EL NO CUMPLIR CON LAS NORMAS ELECTRICAS NACIONALES Y LOCALES, ASI COMO CON LAS RECOMENDACIONES DE FRANKLIN ELECTRIC DURANTE SU INSTALACION, PUEDE OCASIONAR, UN CHOQUE ELECTRICO, PELIGRO DE UN INCENDIO, OPERACION DEFECTUOSA E INCLUSO LA DESCOMPOSTURA DEL EQUIPO. LOS MANUALES DE INSTALACION Y PUESTA EN MARCHA DE LOS EQUIPOS, ESTAN DISPONIBLES CON LOS DISTRIBUIDORES, FABRICANTES DE BOMBAS O DIRECTAMENTE CON FRANKLIN ELECTRIC. PUEDE LLAMAR GRATUITAMENTE PARA MAYOR INFORMACION AL TELEFONO 800-348-2420.

ADVERTENCIA

PUEDE OCURRIR UN CHOQUE ELECTRICO, SERIO O FATAL DEBIDO A UNA ERRONEA CONECCION DEL MOTOR, DE LOS TABLEROS ELECTRICOS, DE LA TUBERIA, DE CUALQUIER OTRA PARTE METALICA QUE ESTA CERCA DEL MOTOR O POR NO UTILIZAR UN CABLE PARA TIERRA DE CALIBRE IGUAL O MAYOR AL DE LA ALIMENTACION. PARA REDUCIR EL RIESGO DE CHOQUE ELECTRIC, DESCONECTAR LA ALIMENTACION ELECTRICA ANTES DE INICIAR A TRABAJAR EN EL SISTEMA HIDRAULICO. NO UTILIZAR ESTE MOTOR EN ALBERCAS O AREAS EN DONDE SE PRACTIQUE NATACION.

Commitment To Quality

Franklin Electric is committed to provide customers with defect free products through our program of continuous improvement. Quality shall, in every case, take precedence over quantity.



Franklin Electric



Submersible Motors

Application • Installation • Maintenance Manual

The submersible motor is a reliable, efficient and trouble-free means of powering a pump. Its needs for a long operational life are simple. They are:

1. A suitable operating environment
2. An adequate supply of electricity
3. An adequate flow of cooling water over the motor
4. An appropriate pump load

All considerations of application, installation, and maintenance of submersible motors relate to these four areas. This manual will acquaint you with these needs and assist you if service or maintenance is required.

Contents

Application - All Motors

Storage	3
Frequency of Starts	3
Mounting Position	3
Transformer Capacity	4
Effects of Torque	4
Engine Driven Generators	5
Use of Check Valves	5
Well Diameters, Casing, Top Feeding, Screens	6
Water Temperature and Flow	6
Flow Inducer Sleeve	6
Head Loss Past Motor	7
Hot Water Applications	7-8
Drawdown Seals	9
Grounding Control Boxes and Panels	9
Grounding Surge Arrestors	9
Control Box and Panel Environment	9

Application - Single Phase Motors

3-Wire Control Boxes	10
2-Wire Motor Solid State Controls	10
QD Relays (Solid State)	10
Cable Selection - 2-Wire or 3-Wire	11
Two Different Cable Sizes	12
Single Phase Motor Specifications	13
Auxiliary Running Capacitors	14
Buck-Boost Transformers	14

Application - Three Phase Motors

Cable Selection - 60°C Three Wire	15-16
Cable Selection - 60°C Six Wire	17
Cable Selection - 75°C Three Wire	18-19
Cable Selection - 75°C Six Wire	20
Three Phase Motor Specifications	21-23
Overload Protection	24-26
Subtrol-Plus	27
Power Factor Correction	27
Submersible Pump Installation Check List (No.3656)	
Submersible Motor Installation Record (No. 2207)	
Submersible Booster Installation Record (No. 3655)	

Three Phase Starter Diagrams	28
Three Phase Power Unbalance	29
Rotation and Current Unbalance	29
Three Phase Motor Lead Identification	30
Phase Converters	30
Reduced Voltage Starters	31
Inline Booster Pump Systems	31-32
Variable Speed Operation	32

Installation - All Motors

Submersible Motors - Dimensions	33
Tightening Lead Connector Jam Nut	34
Pump to Motor Coupling	34
Shaft Height and Free End Play	34
Submersible Leads and Cables	34
Splicing Submersible Cables	35

Maintenance - All Motors

System Trouble Shooting	36-37
Preliminary Tests	38
Insulation Resistance	39
Resistance of Drop Cable	39

Maintenance - Single Phase Motors & Controls

Identification of Cables	40
Single Phase Control Boxes	40
Ohmmeter Tests	41
QD Control Box Parts	42
Integral HP Control Box Parts	43-44
Control Box Wiring Diagrams	45-48

Maintenance - Electronic Products

Pumptec-Plus Trouble Shooting During Installation ..	49
Pumptec-Plus Trouble Shooting After Installation	50
CP Water Trouble Shooting	51
QD PumpteC and PumpteC Trouble Shooting	52
Subtrol-Plus Trouble Shooting	53-54



Application - All Motors

Storage

Franklin Electric submersible motors are a water-lubricated design. The fill solution consists of a mixture of de-ionized water and Propylene Glycol (a non-toxic antifreeze). The solution will prevent damage from freezing in temperatures to -40°F (-40°C); motors should be stored in areas that do not go below this temperature. The solution will partially freeze below 27°F (-3°C), but no damage occurs. Repeated freezing and thawing should be avoided to prevent possible loss of fill solution.

There may be an interchange of fill solution with well water during operation. Care must be taken with motors removed from wells during freezing conditions to prevent damage.

When the storage temperature does not exceed 100°F (37°C), storage time should be limited to two years. Where temperatures reach 100° to 130°F, storage time should be limited to one year.

Loss of a few drops of liquid will not damage the motor as an excess amount is provided, and the filter check valve will allow lost liquid to be replaced by filtered well water upon installation. If there is reason to believe there has been a considerable amount of leakage, consult the factory for checking procedures.

Frequency of Starts

The average number of starts per day over a period of months or years influences the life of a submersible pumping system. Excessive cycling affects the life of control components such as pressure switches, starters, relays and capacitors. Rapid cycling can also cause motor spline damage, bearing damage, and motor overheating. All these conditions can lead to reduced motor life.

The pump size, tank size and other controls should be selected to keep the starts per day as low as practical for longest life. The maximum number of starts per 24-hour period is shown in Table 3.

Motors should run a minimum of one minute to dissipate heat build up from starting current.

Table 3 Number of Starts

Motor Rating		Max Starts Per 24 Hr. Period	
HP	KW	Single Phase	Three Phase
Up to .75 HP	Up to .55	300	300
1 thru 5.5	.75 thru 4	100	300
7.5 thru 30	5.5 thru 22	50	100
40 and over	30 and over		100

Mounting Position

Franklin submersible motors are designed primarily for operation in the vertical, shaft-up position.

During acceleration, the pump thrust increases as its output head increases. In cases where the pump head stays below its normal operating range during startup and full speed condition, the pump may create upward thrust. This creates upward thrust on the motor upthrust bearing. This is an acceptable operation for short periods at each start, but running continuously with upthrust may cause excessive wear on the upthrust bearing.

With certain restrictions, motors are also suitable for operations in positions from shaft-up to shaft-horizontal. As

the mounting position becomes further from vertical and closer to horizontal, the probability of shortened thrust bearing life increases. For normal thrust bearing life expectancy with motor positions other than shaft-up, follow these recommendations:

1. Minimize the frequency of starts, preferably to fewer than 10 per 24-hour period.
2. Do not use in systems which can run even for short periods at full speed without thrust toward the motor.



Application - All Motors

Transformer Capacity - Single Phase or Three Phase

Distribution transformers must be adequately sized to satisfy the KVA requirements of the submersible motor. When transformers are too small to supply the load, there is a reduction in voltage to the motor.

Table 4 references the motor horsepower rating, single phase and three phase, total effective KVA required, and

the smallest transformer required for open or closed three phase systems. Open systems require larger transformers since only two transformers are used.

Other loads would add directly to the KVA sizing requirements of the transformer bank.

Table 4 Transformer Capacity

Motor Rating		Total Effective KVA Required	Smallest KVA Rating-Each Transformer	
			Open WYE or DELTA 2-Transformers	Closed WYE or DELTA 3-Transformers
HP	KW			
1.5	1.1	3	2	1
2	1.5	4	2	1.5
3	2.2	5	3	2
5	3.7	7.5	5	3
7.5	5.5	10	7.5	5
10	7.5	15	10	5
15	11	20	15	7.5
20	15	25	15	10
25	18.5	30	20	10
30	22	40	25	15
40	30	50	30	20
50	37	60	35	20
60	45	75	40	25
75	55	90	50	30
100	75	120	65	40
125	90	150	85	50
150	110	175	100	60
175	130	200	115	70
200	150	230	130	75

NOTE: Standard KVA ratings are shown. If power company experience and practice allows transformer loading higher than standard, higher loading values may be used for transformer(s) to meet total effective KVA required provided correct voltage and balance is maintained.

Effects of Torque

During starting of a submersible pump, the torque developed by the motor must be supported through the pump, delivery pipe or other supports. Most pumps rotate in the direction which causes unscrewing torque on right-handed threaded pipe or pump stages. All threaded joints, pumps and other parts of the pump support system must be capable of withstanding the maximum torque repeatedly without loosening or breaking. Unscrewing joints will break electrical cable and may cause loss of the pump-motor unit.

To safely withstand maximum unscrewing torques with a minimum safety factor of 1.5, tightening all threaded joints to at least 10 lb. ft. per motor horsepower is recommended (Table 4A). It may be necessary to tack or strap weld pipe joints on high horsepower pumps, especially at shallower settings.

Table 4A Torque Required (Examples)

Motor Rating		HP x 10 lb.Ft.	Minimum Safe Torque-Load
HP	KW		
1 HP & Less	.75 KW & Less	1 X 10	10 lb. Ft.
20 HP	15 KW	20 X 10	200 lb. Ft.
75 HP	55 KW	75 x 10	750 lb. Ft.
200 HP	150 KW	200 x 10	2000 lb. Ft.



Application - All Motors

Use of Engine Driven Generators — Single Phase or Three Phase

Table 5 lists minimum generator sizes based on typical 80°C rise continuous duty generators, with 35% maximum voltage dip during starting, for Franklin's three-wire motors, single or three phase.

This is a general chart. The generator manufacturer should be consulted whenever possible, especially on larger sizes.

There are two types of generators available: externally and internally regulated. Most are externally regulated. They use an external voltage regulator that senses the output voltage. As the voltage dips at motor start-up, the regulator increases the output voltage of the generator.

Internally regulated (self-excited) generators have an extra winding in the generator stator. The extra winding senses the output current to automatically adjust the output voltage.

Generators must be sized to deliver at least 65% of the rated voltage during starting to ensure adequate starting torque. Besides sizing, generator frequency is important as the motor speed varies with the frequency (Hz). Due to pump affinity laws, a pump running at 1 to 2 Hz below motor nameplate frequency design will not meet its performance curve. Conversely, a pump running at 1 to 2 Hz above may trip overloads.

Generator Operation. Always start the generator before the motor is started and always stop the motor before the generator is shut down. The motor thrust bearing may be damaged if the generator is allowed to coast down with the motor running. This same condition occurs when the generator is allowed to run out of fuel.

Follow generator manufacturer's recommendations for de-rating at higher elevations or using natural gas.

Use of Check Valves

It is recommended that one or more check valves always be used in submersible pump installations. If the pump does not have a built-in check valve, a line check valve should be installed in the discharge line within 25 feet of the pump and below the draw down level of the water supply. For deeper settings, it is recommended that line check valves be installed per the manufacturer's recommendations.

Swing type check valves are **not** acceptable and should never be used with submersible motors/pumps. Swing type check valves have a slower reaction time which can cause water hammer (see below). Internal pump check valves or spring loaded check valves close quickly and help eliminate water hammer.

Check valves are used to hold pressure in the system when the pump stops. They also prevent backspin, water hammer and upthrust. Any of these can lead to early pump or motor failure.

NOTE: Only positive sealing check valves should be used in submersible installations. Although drilling the check valves or using drain-back check valves may prevent back spinning, they create upthrust and water hammer problems.

Table 5 Engine Driven Generators

Motor Rating		Minimum Rating of Generator			
HP	KW	Externally Regulated		Internally Regulated	
		KW	KVA	KW	KVA
1/3	0.25	1.5	1.9	1.2	1.5
1/2	0.37	2	2.5	1.5	1.9
3/4	0.55	3	3.8	2	2.5
1	0.75	4	5	2.5	3.125
1 1/2	1.1	5	6.25	3	3.8
2	1.5	7.5	9.4	4	5
3	2.2	10	12.5	5	6.25
5	3.7	15	18.75	7.5	9.4
7 1/2	5.5	20	25	10	12.5
10	7.5	30	37.5	15	18.75
15	11	40	50	20	25
20	15	60	75	25	31
25	18.5	75	94	30	37.5
30	22	100	125	40	50
40	30	100	125	50	62.5
50	37	150	188	60	75
60	45	175	220	75	94
75	55	250	313	100	125
100	75	300	375	150	188
125	90	375	469	175	219
150	110	450	563	200	250
175	130	525	656	250	313
200	150	600	750	275	344

NOTE: For best starting of 2-wire motors, the minimum generator rating is 50% higher than shown.

WARNING: To prevent accidental electrocution, automatic or manual transfer switches must be used any time a generator is used as standby or back up on power lines. Contact power company for use and approval.

A.Backspin - With no check valve or a failed check valve, the water in the drop pipe and the water in the system can flow down the discharge pipe when the motor stops. This can cause the pump to rotate in a reverse direction. If the motor is started while this is happening, a heavy strain may be placed across the pump-motor assembly. It can also cause excessive thrust bearing wear because the motor is not turning fast enough to ensure an adequate film of water between the thrust bearing and thrust shoes.

B.Upthrust - With no check valve, or with a leaking check valve, the unit starts under a zero head condition. This causes an uplifting or upthrust on the impeller-shaft assembly in the pump. This upward movement carries across the pump-motor coupling and creates an upthrust condition in the motor. Repeated upthrust can cause premature failure of both the pump and the motor.

C.Water Hammer - If the lowest check valve is more than 30 feet above the standing water level, or a lower check valve leaks and the check valve above holds, a partial vacuum is created in the discharge piping. On the next



Application - All Motors

pump start, water moving at very high velocity fills the void and strikes the closed check valve and the stationary water in the pipe above it, causing a hydraulic shock. This shock can split pipes, break joints and damage the

pump and/or motor. Water hammer is an easily detected noise. When discovered, the system should be shut down and the pump installer contacted to correct the problem.

Wells-Large Diameter, Uncased, Top Feeding & Screened Sections

Franklin Electric submersible motors are designed to operate with a cooling flow of water over the motor. If the pump installation does not provide the minimum flow shown in Table 6, a flow inducer sleeve (flow sleeve) must be used. The conditions requiring a flow sleeve are:

- Well diameter is too large to meet Table 6 flow requirements.

- Pump is in an open body of water.
- Pump is in a rock well or below the well casing.
- The well is “top-feeding”.
- Pump is set in or below screens or perforations.

Water Temperature and Flow

Franklin Electric submersible motors, except 8" SEVERE DUTY (see note below), are designed to operate up to maximum service factor horsepower in water up to 86°F (30°C). A flow of 0.25 ft/sec for 4" High Thrust motors and 0.5 ft/sec for 6 and 8 inch motors is required for proper cooling. Table 6 shows minimum flow rates, in GPM, for various well diameters and motor sizes.

If the motor is operated in water over 86°F (30°C), water flow past the motor must be increased to maintain safe motor operating temperatures. See HOT WATER APPLICATIONS on Page 7.

NOTE: 8" SEVERE DUTY motors are designed to operate with loading up to maximum service factor horsepower in water up to 90°C (195°F) with water flow past motor of 0.5 ft/sec (0.15 m/sec).

Table 6 Required Cooling Flow

Minimum GPM required for motor cooling in water up to 86°F (30°C).			
Casing or Sleeve I.D. Inches (mm)	4" High Thrust Motor .25 ft/sec. GPM (l/m)	6" Motor .50 ft/sec. GPM (l/m)	8" Motor .50 ft/sec. GPM (l/m)
4 (102)	1.2 (4.5)	-	-
5 (127)	7 (26.5)	-	-
6 (152)	13 (49)	9 (34)	-
7 (178)	20 (76)	25 (95)	-
8 (203)	30 (114)	45 (170)	10 (40)
10 (254)	50 (189)	90 (340)	55 (210)
12 (305)	80 (303)	140 (530)	110 (420)
14 (356)	110 (416)	200 (760)	170 (645)
16 (406)	150 (568)	280 (1060)	245 (930)

.25 ft/sec = 7.62 cm/sec .50 ft/sec = 15.24 cm/sec
1 inch = 2.54 cm

Flow Inducer Sleeve

If the flow rate is less than specified or coming from above the pump, then a flow inducer sleeve must be used. A flow sleeve is always required in an open body of water. FIG 1 shows a typical flow inducer sleeve construction.

EXAMPLE : A six-inch motor and pump that delivers 60 GPM will be installed in a 10" well.

From Table 6, 90 GPM would be required to maintain proper cooling. In this case adding an 8" or smaller flow sleeve provides the required cooling.

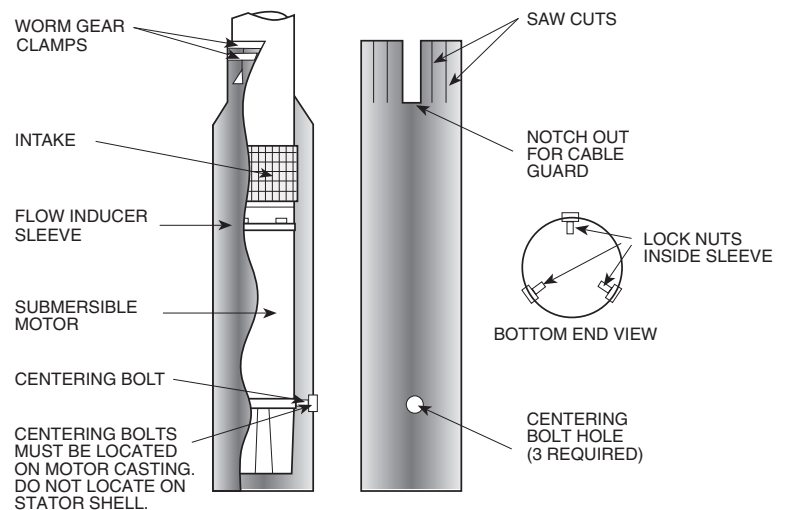

FIG. 1



Application - All Motors

Head Loss From Flow Past Motor

Table 7 lists the approximate head loss due to flow between an average length motor and smooth casing or flow inducer sleeve.

Table 7 Head Loss in Feet (Meters) at Various Flow Rates

Motor Diameter		4"	4"	4"	6"	6"	6"	8"	8"
Casing ID in Inches (mm)		4 (102)	5 (127)	6 (152)	6 (152)	7 (178)	8 (203)	8.1 (206)	10 (254)
Flow Rate in GPM (l/m)	25 (95)	0.3 (.09)							
	50 (189)	1.2 (.37)							
	100 (378)	4.7 (1.4)	0.3 (.09)		1.7 (.52)				
	150 (568)	10.2 (3.1)	0.6 (.18)	0.2 (.06)	3.7 (1.1)				
	200 (757)		1.1 (.34)	0.4 (.12)	6.3 (1.9)	0.5 (.15)		6.8 (2.1)	
	250 (946)		1.8 (.55)	0.7 (.21)	9.6 (2.9)	0.8 (.24)		10.4 (3.2)	
	300 (1136)		2.5 (.75)	1.0 (.30)	13.6 (4.1)	1.2 (.37)	0.2 (.06)	14.6 (4.5)	
	400 (1514)				23.7 (7.2)	2.0 (.61)	0.4 (.12)	24.6 (7.5)	
	500 (1893)					3.1 (.94)	0.7 (.21)	37.3 (11.4)	0.6 (0.2)
	600 (2271)					4.4 (1.3)	1.0 (.30)	52.2 (15.9)	0.8 (0.3)
	800 (3028)								1.5 (0.5)
1000 (3785)								2.4 (0.7)	

Hot Water Applications

When the pump-motor operates in water hotter than 86°F (30°C), a flow rate of at least 3 ft/sec is required. When selecting the motor to drive a pump in over 86°F (30°C) water, the motor horsepower must be de-rated per the following procedure.

- Using Table 7A, determine pump GPM required for different well or sleeve diameters. If necessary, add a flow sleeve to obtain at least 3 ft/sec flow rate.

Table 7A - Minimum GPM (l/m) Required for 3 ft/sec (.91 m/sec) Flow Rate

Casing or Sleeve I.D.		4" High Thrust Motor		6" Motor		8" Motor	
Inches	(mm)	GPM	(l/m)	GPM	(l/m)	US GPM	(l/m)
4	(102)	15	(57)				
5	(127)	80	(303)				
6	(152)	160	(606)	52	(197)		
7	(178)			150	(568)		
8	(203)			260	(984)	60	(227)
10	(254)			520	(1970)	330	(1250)
12	(305)					650	(2460)
14	(356)					1020	(3860)
16	(406)					1460	(5530)



Application - All Motors

2. Determine pump horsepower required from the pump manufacturer's curve.

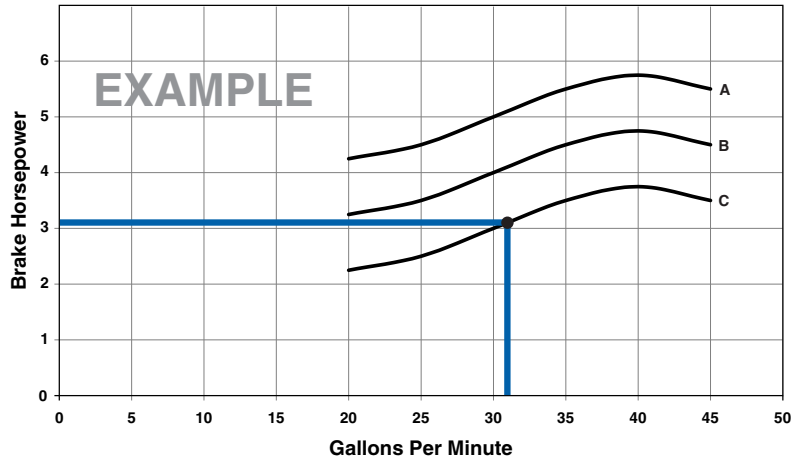

FIG. 2 MANUFACTURER'S PUMP CURVE

Table 8 Heat Factor Multiplier at 3 ft/sec (.91 m/sec) Flow Rate

3. Multiply the pump horsepower required by the heat factor multiplier from Table 8.

Maximum Water Temperature	1/3 - 5 HP .25 - 3.7 KW	7 1/2 - 30 HP 5.5 - 22 KW	Over 30HP Over 22 KW
140°F (60°C)	1.25	1.62	2.00
131°F (55°C)	1.11	1.32	1.62
122°F (50°C)	1.00	1.14	1.32
113°F (45°C)	1.00	1.00	1.14
104°F (40°C)	1.00	1.00	1.00
95°F (35°C)	1.00	1.00	1.00

Table 8A Service Factor Horsepower

4. Select a rated HP motor on Table 8A whose Service Factor Horsepower is at least the value calculated in Item 3.

HP	KW	SFHP	HP	KW	SFHP	HP	KW	SFHP	HP	KW	SFHP
1/3	0.25	0.58	3	2.2	3.45	25	18.5	28.75	100	75	115
1/2	0.37	0.8	5	3.7	5.75	30	22	34.5	125	90	143.75
3/4	0.55	1.12	7 1/2	5.5	8.62	40	30	46	150	110	175.5
1	0.75	1.4	10	7.5	11.5	50	37	57.5	175	130	201.25
1 1/2	1.1	1.95	15	11	17.25	60	45	69	200	150	230
2	1.5	2.5	20	15	23	75	55	86.25			

Hot Water Applications - Example

EXAMPLE: A 6" pump end requiring 39 HP input will pump 124°F water in an 8" well at a delivery rate of 140 GPM. From Table 7A, a 6" flow sleeve will be required to increase the flow rate to at least 3 ft/sec.

Using Table 8, the 1.62 heat factor multiplier is selected because the HP required is over 30 HP and water temperature is above 122°F. Multiply 39 HP x 1.62 (multiplier), which equals 63.2 HP. This is the minimum rated service factor horsepower usable at 39 HP in 124°F. Using

Table 8A, select a motor with a rated service factor horsepower above 63.2 HP. A 60 HP motor has a service factor horsepower of 69, so a 60 HP motor may be used.

For many hot water applications Franklin Electric's 8" SEVERE DUTY MOTOR is more economical than a de-rated 8" standard water well motor. See SEVERE DUTY MOTOR application manual for additional options for hot water pumping.



Application - All Motors

Drawdown Seals

Allowable motor temperature is based on atmospheric pressure or higher surrounding the motor. "Drawdown seals," which seal the well to the pump above its intake to

maximize delivery, are not recommended, since the suction created can be lower than atmospheric pressure.

Grounding Control Boxes and Panels

The National Electrical Code requires that the control box or panel-grounding terminal always be connected to supply ground. If the circuit has no grounding conductor and no metal conduit from the box to supply panel, use a wire at least as large as line conductors and connect as required by the National Electrical Code, from the grounding terminal to the electrical supply ground.

WARNING: Failure to ground the control frame can result in a serious or fatal electrical shock hazard if a circuit fault occurs.

Grounding Surge Arrestors

An above ground surge arrestor must be grounded, metal to metal, all the way to the water strata for the lightning arrestor to be effective. GROUNDING THE ARRESTOR TO THE SUPPLY GROUND OR TO A DRIVEN GROUND ROD PROVIDES LITTLE OR NO PROTECTION FOR THE MOTOR.

Control Box and Panel Environment

Franklin Electric control boxes meet UL requirements for NEMA Type 3R enclosures. They are suitable for indoor and outdoor applications within temperatures of +14°F (-10°C) to 122°F (50°C). Operating control boxes below +14° F can cause reduced starting torque and loss of overload protection when overloads are located in control boxes.

Control boxes and panels should never be mounted in direct sunlight or high temperature locations. This will

cause shortened capacitor life and unnecessary tripping of overload protectors. A ventilated enclosure painted white to reflect heat is recommended for an outdoor, high temperature location.

A damp well pit, or other humid location, accelerates component failure from voltage breakdown and corrosion. Control boxes with voltage relays are designed for vertical upright mounting only. Mounting in other positions will affect the operation of the relay.



Application - Single Phase Motors

3-Wire Control Boxes

Single phase three-wire submersible motors require the use of control boxes. Operation of motors without control boxes or with incorrect boxes can result in motor failure and voids warranty.

Control boxes contain starting capacitors, a starting relay, and, in some sizes, overload protectors, running capacitors and contactors.

Ratings through 1 HP may use a solid state or a potential (voltage) type starting relay, while larger ratings use potential relays.

Potential (Voltage) Relays

Potential relays have normally closed contacts. When power is applied, both start and main motor windings are

energized, and the motor starts. At this instant, the voltage across the start winding is relatively low and not enough to open the contacts of the relay.

As the motor accelerates, the increasing voltage across the start winding (and the relay coil) opens the relay contacts. This opens the starting circuit and the motor continues to run on the main winding alone, or the main plus run capacitor circuit. After the motor is started the relay contacts remain open.

CAUTION: Be certain that control box HP and voltage match the motor.

2-Wire Motor Solid State Controls

BIAC Switch Operation

When power is applied the bi-metal switch contacts are closed so the triac is conducting and energizes the start winding. As RPM increases, the voltage in the sensor coil generates heat in the bi-metal strip, causing the bi-metal strip to bend and open the switch circuit. This removes the starting winding and the motor continues to run on the main winding alone.

Approximately 5 seconds after power is removed from the motor, the bi-metal strip cools sufficiently to return to its closed position and the motor is ready for the next start cycle. If, during operation, the motor speed drops, the lowered voltage in the sensor coil allows the bi-metal contacts to close, and bring the motor back to operating speed.

CAUTION: Restarting the motor within 5 seconds after power is removed may cause the motor overload to trip.

Rapid Cycling

The BIAC starting switch will reset within approximately 5 seconds after the motor is stopped. If an attempt is made to restart the motor before the starting switch has reset, the motor may not start; however, there will be current in the main winding until the overload protector interrupts the circuit. The time for the protector to reset is longer than the reset of the starting switch. Therefore, the start switch will have closed and the motor will operate.

A waterlogged tank will cause fast cycling. When a waterlogged condition does occur, the user will be alerted to the problem during the off time (overload reset time) since the pressure will drop drastically. When the waterlogged tank condition is detected the condition should be corrected to prevent nuisance tripping of the overload protector.

Bound Pump (Sandlocked)

When the motor is not free to turn, as with a sandlocked pump, the BIAC switch creates a "reverse impact torque" in the motor in either direction. When the sand is dislodged, the motor will start and operate in the correct direction.

QD Relays (Solid State)

There are two elements in the relay: a reed switch and a triac. The reed switch consists of two tiny rectangular blade-type contacts, which bend under magnetic flux. It is hermetically sealed in glass and is located within a coil, which conducts line current. When power is supplied to the control box, the main winding current passing through the coil immediately closes the reed switch contacts. This turns on the triac, which supplies voltage to the start winding, thus starting the motor.

Once the motor is started, the operation of the QD relay is an interaction between the triac, the reed switch and the

motor windings. The solid state switch senses motor speed through the changing phase relationship between start winding current and line current. As the motor approaches running speed, the phase angle between the start current and the line current become nearly in phase. At this point, the reed switch contacts open, turning off the triac. This removes voltage from the start winding and the motor continues to run on the main winding only. With the reed switch contacts open and the triac turned off, the QD relay is ready for the next starting cycle.



Application - Single Phase Motors

2- or 3-Wire Cable, 60 HZ (Service Entrance to Motor - Maximum Length In Feet)

Table 11

Motor Rating			60° C Insulation - AWG Copper Wire Size												
Volts	HP	KW	14	12	10	8	6	4	3	2	1	0	00	000	0000
115	1/3	.25	130	210	340	540	840	1300	1610	1960	2390	2910	3540	4210	5060
	1/2	.37	100	160	250	390	620	960	1190	1460	1780	2160	2630	3140	3770
230	1/3	.25	550	880	1390	2190	3400	5250	6520	7960	9690	11770			
	1/2	.37	400	650	1020	1610	2510	3880	4810	5880	7170	8720			
	3/4	.55	300	480	760	1200	1870	2890	3580	4370	5330	6470	7870		
	1	.75	250	400	630	990	1540	2380	2960	3610	4410	5360	6520		
	1 1/2	1.1	190	310	480	770	1200	1870	2320	2850	3500	4280	5240		
	2	1.5	150	250	390	620	970	1530	1910	2360	2930	3620	4480		
	3	2.2	120	190	300	470	750	1190	1490	1850	2320	2890	3610		
	5	3.7	0	0	180	280	450	710	890	1110	1390	1740	2170	2680	
	7 1/2	5.5	0	0	0	200	310	490	610	750	930	1140	1410	1720	
	10	7.5	0	0	0	0	250	390	490	600	750	930	1160	1430	1760
15	11	0	0	0	0	170	270	340	430	530	660	820	1020	1260	

Table 11A

Motor Rating			75° C Insulation - AWG Copper Wire Size												
Volts	HP	KW	14	12	10	8	6	4	3	2	1	0	00	000	0000
115	1/3	.25	130	210	340	540	840	1300	1610	1960	2390	2910	3540	4210	5060
	1/2	.37	100	160	250	390	620	960	1190	1460	1780	2160	2630	3140	3770
230	1/3	.25	550	880	1390	2190	3400	5250	6520	7960	9690				
	1/2	.37	400	650	1020	1610	2510	3880	4810	5880	7170	8720			
	3/4	.55	300	480	760	1200	1870	2890	3580	4370	5330	6470	7870	9380	
	1	.75	250	400	630	990	1540	2380	2960	3610	4410	5360	6520	7780	9350
	1 1/2	1.1	190	310	480	770	1200	1870	2320	2850	3500	4280	5240	6300	7620
	2	1.5	150	250	390	620	970	1530	1910	2360	2930	3620	4480	5470	6700
	3	2.2	120	190	300	470	750	1190	1490	1850	2320	2890	3610	4470	5550
	5	3.7	0	110	180	280	450	710	890	1110	1390	1740	2170	2680	3330
	7 1/2	5.5	0	0	120	200	310	490	610	750	930	1140	1410	1720	2100
	10	7.5	0	0	0	160	250	390	490	600	750	930	1160	1430	1760
15	11	0	0	0	0	170	270	340	430	530	660	820	1020	1260	

1 Foot = .3048 Meter

Lengths **not** in bold type meet the U.S. National Electrical Code ampacity for either individual conductors or jacketed 60°C or 75°C cable.

Lengths in bold type meet the National Electric Code ampacity only for individual conductor 60°C or 75°C cable, in free air or water, not in magnetic enclosure or conduit. If any other cable is used, the National Electric Code as well as the local codes should be observed. Flat molded and web cable is considered jacketed cable.

Cable lengths in Table 11 & 11A allow for a 5% voltage drop running at maximum nameplate amperes. If 3% voltage drop is desired multiply Table 11 and 11A lengths by .6 to get maximum cable length.

Table 11 & 11A is based on copper wire. If aluminum wire

is used, it must be two sizes larger than copper wire and oxidation inhibitors must be used on connections.

EXAMPLE: If Table 11 & 11A calls for #12 copper wire, #10 aluminum wire would be required.

The portion of the total cable length which is between the supply and single phase control box, with a line contactor, should not exceed 25% of total maximum allowable to ensure reliable contactor operation. Single phase control boxes without line contactors may be connected at any point in the total cable length.

Contact Franklin Electric for 90°C cable lengths. See pages 14, 42, and 43 for applications using 230V motors on 208V power systems.



Application - Single Phase Motors

Two different cable sizes can be used.

Depending on the installation, any number of combinations of cable may be used.

For example, in a replacement installation, the well already has 160 feet of buried #10 cable between the service entrance and the well head. The question is: What size cable is required in the well with a 3 HP, 230 volt, single phase motor setting at 310 feet?

1. From Table 11 & 11A, a 3 HP motor can use up to 300 feet of #10 AWG cable.
2. The application has 160 feet of buried #10 AWG cable.
3. $160 \text{ feet} \div 300 \text{ feet (max allowable)}$ is equal to 53.3% of max allowable.

4. $100\% - 53.3\% = 46.7\%$ remaining of another size cable.
5. 310 feet (well head to motor) is 46.7% of max allowable length of another cable size.
6. $310 \text{ feet} \div .467 (46.7\%) = 664 \text{ feet}$ is max allowable.
7. 664 feet is less than or equal to what size cable in Table 11 or 11A under the 3 HP listing?

The table shows #8 is good for 470 feet, which is too short. #6 is good for 750 feet, therefore #6 can be used for the remaining 310 feet.

EXAMPLE: 3 HP, 230 Volt, 1 PH Motor

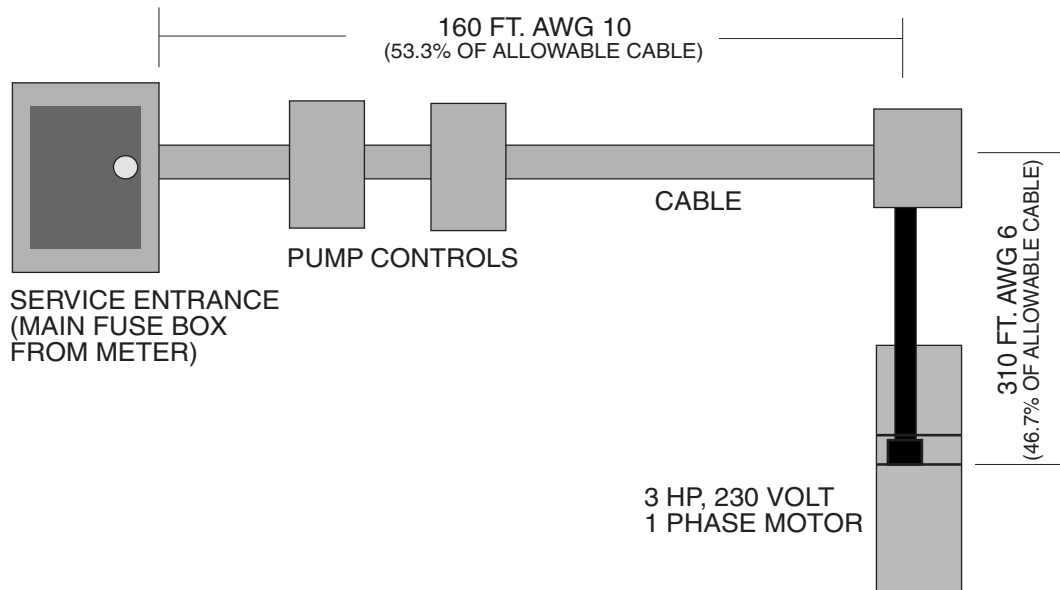



Application - Single Phase Motors

Table 13 Single Phase Motor Specifications (60 Hz) 3450 RPM

Type	Motor Model Prefix	Rating					Full Load (2) Amps	Maximum (S.F. Load) (2) Amps	Winding (1) Res. In Ohms M=Main Res. S=Start Res.	Efficiency %			Power Factor %			Locked Rotor AMPS	KVA Code	Circuit Breakers or Fuse Amps		
		HP	KW	Volts	Hz	S.F.				S.F.	F.L.	3/4	S.F.	F.L.	3/4			Nontime Delay (Std.) Fuse	Dual Element Time Delay Fuse	Inverse Time Breaker
4 Inch 2 - Wire	244502	1/3	0.25	115	60	1.75	8.0	9.2	1.4-1.8	60	51	45	71	54	47	48.4	S	25	15	20
	244503	1/3	0.25	230	60	1.75	4.0	4.6	6.0-7.4	60	51	45	71	54	47	24.2	S	15	8	15
	244504	1/2	0.37	115	60	1.60	10.0	12.0	1.0-1.3	62	55	49	73	58	50	64.4	R	35	20	30
	244505	1/2	0.37	230	60	1.60	5.0	6.0	4.2-5.2	62	55	49	73	58	50	32.2	R	20	10	15
	244507	3/4	0.55	230	60	1.50	6.8	8.0	3.0-3.6	64	59	53	74	62	53	40.7	N	25	15	20
	244508	1	0.75	230	60	1.40	8.2	9.8	2.2-2.7	65	62	57	74	63	54	48.7	N	30	20	25
244309	1 1/2	1.1	230	60	1.30	10.6	13.1	1.5-1.9	65	63	59	80	74	66	66.6	M	35	20	30	
4 Inch 3 - Wire	214502	1/3	0.25	115	60	1.75	Y8.0 B8.0 R0	Y9.2 B9.2 R0	M1.4-1.8 S6.5-7.9	60	51	45	71	54	47	34.8	N	25	15	20
	214503	1/3	0.25	230	60	1.75	Y4.0 B4.0 R0	Y4.6 B4.6 R0	M6.0-7.4 S26.1-32.0	60	51	45	71	54	47	17.2	N	15	8	15
	214504	1/2	0.37	115	60	1.60	Y10.0 B10.0 R0	Y12.0 B12.0 R0	M1.0-1.3 S4.1-5.1	62	55	49	73	58	50	50.5	M	35	20	30
	214505	1/2	0.37	230	60	1.60	Y5.0 B5.0 R0	Y6.0 B6.0 R0	M4.2-5.2 S16.7-20.5	62	55	49	73	58	50	23.0	M	20	10	15
	214507	3/4	0.55	230	60	1.50	Y6.8 B6.8 R0	Y8.0 B8.0 R0	M3.0-3.6 S11.0-13.4	64	59	53	74	62	53	34.2	M	25	15	20
	214508	1	0.75	230	60	1.40	Y8.2 B8.2 R0	Y9.8 B9.8 R0	M2.2-2.7 S10.1-12.3	65	62	57	74	63	54	41.8	L	30	20	25
4 Inch 3 - Wire with Run Cap	224300	1 1/2	1.1	230	60	1.30	Y10.0 B9.9 R1.3	Y11.5 B11.0 R1.3	M1.5-2.3 S6.2-12.0	68	66	62	81	74	66	52.0	J	35	20	30
	224301	2	1.5	230	60	1.25	Y10.0 B9.3 R2.6	Y13.2 B11.9 R2.6	M1.6-2.3 S5.2-7.15	70	71	69	93	91	87	51.0	G	30	20	25
	224302	3	2.2	230	60	1.15	Y14.0 B12.2 R4.7	Y17.0 B14.5 R4.5	M.9-1.5 S3.0-4.9	71	72	70	98	98	96	82.0	G	45	30	40
	224303	5	3.7	230	60	1.15	Y23.0 B19.1 R8.0	Y27.5 B23.2 R7.8	M.68-1.0 S2.1-2.8	71	72	70	98	96	94	121.0	F	80	45	60
6 Inch	226110	5	3.7	230	60	1.15	Y23.0 B18.2 R8.0	Y27.5 B23.2 R7.8	M.55-.68 S1.3-1.6	76	75	72	98	98	99	99.0	E	80	45	60
	226111	7 1/2	5.5	230	60	1.15	Y36.5 B34.4 R5.5	Y42.1 B40.5 R5.4	M.36-.50 S.92-1.2	73	74	74	91	90	87	165.0	F	125	70	100
	226112	10	7.5	230	60	1.15	Y44.0 B39.5 R9.3	Y51.0 B47.5 R8.9	M.27-.33 S.80-.99	76	77	76	96	96	95	204.0	E	150	80	125
	226113	15	11	230	60	1.15	Y62.0 B52.0 R17.5	Y75.0 B62.5 R16.9	M.17-.22 S.68-.93	79	80	80	97	98	98	303.0	E	200	125	175

- (1) Main winding - yellow to black
Start winding - yellow to red
- (2) Y = Yellow lead - line amps
B = Black lead - main winding amp
R = Red lead - start or auxiliary winding amps

Performance is typical, not guaranteed, at specified voltages and specified capacitor values.

Performance at voltage ratings not shown is similar, except amps vary inversely with voltage.



Application - Single Phase Motors

Auxiliary Running Capacitors

Added capacitors must be connected across “Red” and “Black” control box terminals, in parallel with any existing running capacitors. The additional capacitor(s) should be mounted in an auxiliary box. The values of additional running capacitors most likely to reduce noise are given below. The tabulation gives the S.F. amps normally in each lead with the added capacitor.

Table 14 Auxiliary Capacitor Sizing

Motor Rating		Normal Running Capacitor(s) Mfd.	Auxiliary Running Capacitors For Noise Reduction			S.F. Amps with Run Cap		
HP	Volts		Mfd	Min. Volts	Franklin Part	Yellow	Black	Red
1/3	115	0	45(1)	370	One 155327109	6.3	5.3	2.9
1/2		0	60(1)	370	Two 155327101	8.4	7.0	4.0
1/3	230	0	10(1)	370	One 155328102	3.3	3.1	1.2
1/2		0	15(1)	370	One 155328101	4.2	3.5	2.0
3/4		0	20(1)	370	One 155328103	5.8	5.0	2.5
1		0	25(1)	370	One ea. 155328101 155328102	7.1	5.6	3.4
1 1/2		10	20	370	One 155328103	9.3	7.5	4.4
2		20	10	370	One 155328102	11.2	9.2	3.8
3		35	10	370	One 155328102	16.1	13.0	5.9
5		60	None	370		27.5	23.2	7.8
7 1/2		45	45	370	One ea. 155327101 155328101	37.0	32.0	11.3
10		70	30	370	One 155327101	49.0	42.0	13.0
15	135	None			75.0	62.5	16.9	

- (1) Do not add running capacitors to standard production 1/3 through 1 HP control boxes, which use current relays, solid state starting switches or QD relays! Adding capacitors will cause switch failure. If the control box is converted to use a voltage relay, the specified running capacitance can be added.

Buck-Boost Transformers

When the available power supply voltage is not within the proper range, a buck-boost transformer is often used to adjust voltage to match the motor. The most common usage on submersible motors is boosting a 208 volt supply to use a standard 230 volt single phase submersible motor and control. While tables to give a wide range of voltage

boost or buck are published by transformer manufacturers, the following table shows Franklin’s recommendations. The table, based on boosting the voltage 10%, shows the minimum rated transformer KVA needed and the common standard transformer KVA.

Table 14A Buck-Boost Transformer Sizing

Motor HP	1/3	1/2	3/4	1	1 1/2	2	3	5	7 1/2	10	15
Load KVA	1.02	1.36	1.84	2.21	2.65	3.04	3.91	6.33	9.66	11.70	16.60
Minimum XFMR KVA	0.11	0.14	0.19	0.22	0.27	0.31	0.40	0.64	0.97	1.20	1.70
Standard XFMR KVA	0.25	0.25	0.25	0.25	0.50	0.50	0.50	0.75	1.00	1.50	2.00

Buck-Boost transformers are power transformers, not control transformers. They may also be used to lower voltage when the available power supply voltage is too high.



Application - Three Phase Motors

Table 15 Three Phase 60°C Cable, 60 Hz (Service Entrance to Motor) Maximum Length in Feet

Motor Rating			60°C Insulation - AWG Copper Wire Size												MCM Copper Wire Size							
Volts	HP	KW	14	12	10	8	6	4	3	2	1	0	00	000	0000	250	300	350	400	500		
200 v 60Hz Three Phase 3 - Lead	1/2	0.37	710	1140	1800	2840	4420															
	3/4	0.55	510	810	1280	2030	3160															
	1	0.75	430	690	1080	1710	2670	4140	5140													
	1 1/2	1.1	310	500	790	1260	1960	3050	3780													
	2	1.5	240	390	610	970	1520	2360	2940	3610	4430	5420										
	3	2.2	180	290	470	740	1160	1810	2250	2760	3390	4130										
	5	3.7	110	170	280	440	690	1080	1350	1660	2040	2490	3050	3670	4440	5030						
	7 1/2	5.5	0	0	200	310	490	770	960	1180	1450	1770	2170	2600	3150	3560						
	10	7.5	0	0	0	230	370	570	720	880	1090	1330	1640	1970	2390	2720	3100	3480	3800	4420		
	15	11	0	0	0	160	250	390	490	600	740	910	1110	1340	1630	1850	2100	2350	2570	2980		
	20	15	0	0	0	0	190	300	380	460	570	700	860	1050	1270	1440	1650	1850	2020	2360		
	25	18.5	0	0	0	0	0	240	300	370	460	570	700	840	1030	1170	1330	1500	1640	1900		
30	22	0	0	0	0	0	0	250	310	380	470	580	700	850	970	1110	1250	1360	1590			
230V 60 Hz Three Phase 3 - Lead	1/2	0.37	930	1490	2350	3700	5760	8910														
	3/4	0.55	670	1080	1700	2580	4190	6490	8060	9860												
	1	0.75	560	910	1430	2260	3520	5460	6780	8290												
	1 1/2	1.1	420	670	1060	1670	2610	4050	5030	6160	7530	9170										
	2	1.5	320	510	810	1280	2010	3130	3890	4770	5860	7170	8780									
	3	2.2	240	390	620	990	1540	2400	2980	3660	4480	5470	6690	8020	9680							
	5	3.7	140	230	370	590	920	1430	1790	2190	2690	3290	4030	4850	5870	6650	7560	8460	9220			
	7 1/2	5.5	0	160	260	420	650	1020	1270	1560	1920	2340	2870	3440	4160	4710	5340	5970	6500	7510		
	10	7.5	0	0	190	310	490	760	950	1170	1440	1760	2160	2610	3160	3590	4100	4600	5020	5840		
	15	11	0	0	0	210	330	520	650	800	980	1200	1470	1780	2150	2440	2780	3110	3400	3940		
	20	15	0	0	0	0	250	400	500	610	760	930	1140	1380	1680	1910	2180	2450	2680	3120		
	25	18.5	0	0	0	0	0	320	400	500	610	750	920	1120	1360	1540	1760	1980	2160	2520		
30	22	0	0	0	0	0	260	330	410	510	620	760	930	1130	1280	1470	1650	1800	2110			
380V 60 Hz Three Phase 3 - Lead	1/2	0.37	2690	4290	6730																	
	3/4	0.55	2000	3190	5010	7860																
	1	0.75	1620	2580	4060	6390	9980															
	1 1/2	1.1	1230	1970	3100	4890	7630															
	2	1.5	870	1390	2180	3450	5400	8380														
	3	2.2	680	1090	1710	2690	4200	6500	8020	9830												
	5	3.7	400	640	1010	1590	2490	3870	4780	5870	7230	8830										
	7 1/2	5.5	270	440	690	1090	1710	2640	3260	4000	4930	6010	7290	8780								
	10	7.5	200	320	510	800	1250	1930	2380	2910	3570	4330	5230	6260	7390	8280	9340					
	15	11	0	0	370	590	920	1430	1770	2170	2690	3290	4000	4840	5770	6520	7430	8250	8990			
	20	15	0	0	0	440	700	1090	1350	1670	2060	2530	3090	3760	4500	5110	5840	6510	7120	8190		
	25	18.5	0	0	0	360	570	880	1100	1350	1670	2050	2510	3040	3640	4130	4720	5250	5740	6590		
	30	22	0	0	0	0	470	730	910	1120	1380	1700	2080	2520	3020	3430	3920	4360	4770	5490		
	40	30	0	0	0	0	0	530	660	820	1010	1240	1520	1840	2200	2500	2850	3170	3470	3990		
	50	37	0	0	0	0	0	0	540	660	820	1000	1220	1480	1770	2010	2290	2550	2780	3190		
	60	45	0	0	0	0	0	0	0	560	690	850	1030	1250	1500	1700	1940	2150	2350	2700		
	75	55	0	0	0	0	0	0	0	0	570	700	860	1050	1270	1440	1660	1850	2030	2350		
	100	75	0	0	0	0	0	0	0	0	0	510	630	760	910	1030	1180	1310	1430	1650		
125	90	0	0	0	0	0	0	0	0	0	0	0	620	740	840	950	1060	1160	1330			
150	110	0	0	0	0	0	0	0	0	0	0	0	0	620	700	790	880	960	1090			
175	130	0	0	0	0	0	0	0	0	0	0	0	0	0	650	750	840	920	1070			
200	150	0	0	0	0	0	0	0	0	0	0	0	0	0	0	630	700	760	880			

Continued on page 16



Application - Three Phase Motors

Table 16 Three Phase 60°C Cable (Continued)

Motor Rating			60°C Insulation - AWG Copper Wire Size													MCM Copper Wire Size					
Volts	HP	KW	14	12	10	8	6	4	3	2	1	0	00	000	0000	250	300	350	400	500	
460V 60Hz Three Phase 3 - Lead	1/2	0.37	3770	6020	9460																
	3/4	0.55	2730	4350	6850																
	1	0.75	2300	3670	5770	9070															
	1 1/2	1.1	1700	2710	4270	6730															
	2	1.5	1300	2070	3270	5150	8050														
	3	2.2	1000	1600	2520	3970	6200														
	5	3.7	590	950	1500	2360	3700	5750													
	7 1/2	5.5	420	680	1070	1690	2640	4100	5100	6260	7680										
	10	7.5	310	500	790	1250	1960	3050	3800	4680	5750	7050									
	15	11	0	340	540	850	1340	2090	2600	3200	3930	4810	5900	7110							
	20	15	0	0	410	650	1030	1610	2000	2470	3040	3730	4580	5530							
	25	18.5	0	0	0	530	830	1300	1620	1990	2450	3010	3700	4470	5430						
	30	22	0	0	0	430	680	1070	1330	1640	2030	2490	3060	3700	4500	5130	5860				
	40	30	0	0	0	0	500	790	980	1210	1490	1830	2250	2710	3290	3730	4250				
	50	37	0	0	0	0	0	640	800	980	1210	1480	1810	2190	2650	3010	3420	3830	4180	4850	
	60	45	0	0	0	0	0	540	670	830	1020	1250	1540	1850	2240	2540	2890	3240	3540	4100	
	75	55	0	0	0	0	0	0	0	680	840	1030	1260	1520	1850	2100	2400	2700	2950	3440	
	100	75	0	0	0	0	0	0	0	0	620	760	940	1130	1380	1560	1790	2010	2190	2550	
	125	90	0	0	0	0	0	0	0	0	0	0	740	890	1000	1220	1390	1560	1700	1960	
	150	110	0	0	0	0	0	0	0	0	0	0	0	760	920	1050	1190	1340	1460	1690	
175	130	0	0	0	0	0	0	0	0	0	0	0	0	810	930	1060	1190	1300	1510		
200	150	0	0	0	0	0	0	0	0	0	0	0	0	0	810	920	1030	1130	1310		
575V 60 Hz Three Phase 3 - Lead	1/2	0.37	5900	9410																	
	3/4	0.55	4270	6810																	
	1	0.75	3630	5800	9120																
	1 1/2	1.1	2620	4180	6580																
	2	1.5	2030	3250	5110	8060															
	3	2.2	1580	2530	3980	6270															
	5	3.7	920	1480	2330	3680	5750														
	7 1/2	5.5	660	1060	1680	2650	4150														
	10	7.5	490	780	1240	1950	3060	4770	5940												
	15	11	330	530	850	1340	2090	3260	4060												
	20	15	0	410	650	1030	1610	2520	3140	3860	4760	5830									
	25	19	0	0	520	830	1300	2030	2530	3110	3840	4710									
	30	22	0	0	430	680	1070	1670	2080	2560	3160	3880	4770	5780	7030	8000					
	40	30	0	0	0	500	790	1240	1540	1900	2330	2860	3510	4230	5140	5830					
	50	37	0	0	0	0	640	1000	1250	1540	1890	2310	2840	3420	4140	4700	5340	5990	6530	7580	
	60	45	0	0	0	0	0	850	1060	1300	1600	1960	2400	2890	3500	3970	4520	5070	5530	6410	
	75	55	0	0	0	0	0	690	860	1060	1310	1600	1970	2380	2890	3290	3750	5220	4610	5370	
	100	75	0	0	0	0	0	0	0	790	970	1190	1460	1770	2150	2440	2790	3140	3430	3990	
	125	90	0	0	0	0	0	0	0	0	770	950	1160	1400	1690	1920	2180	2440	2650	3070	
	150	110	0	0	0	0	0	0	0	0	0	800	990	1190	1440	1630	1860	2080	2270	2640	
175	130	0	0	0	0	0	0	0	0	0	0	870	1050	1270	1450	1650	1860	2030	2360		
200	150	0	0	0	0	0	0	0	0	0	0	0	920	1110	1260	1440	1620	1760	2050		

See Footnotes on Page 11 for information on bold figures.



Application - Three Phase Motors

Table 17 Three Phase 60°C Cable (Continued)

Motor Rating			60°C Insulation - AWG Copper Wire Size													MCM Copper Wire Size					
Volts	HP	KW	14	12	10	8	6	4	3	2	1	0	00	000	0000	250	300	350	400	500	
200V 60Hz Three Phase 6 - Lead Y-D	5	3.7	160	250	420	660	1030	1620	2020	2490	3060	3730	4570	5500	6660	7540					
	7 1/2	5.5	110	180	300	460	730	1150	1440	1770	2170	2650	3250	3900	4720	5340					
	10	7.5	80	130	210	340	550	850	1080	1320	1630	1990	2460	2950	3580	4080	4650	5220	5700	6630	
	15	11	0	0	140	240	370	580	730	900	1110	1360	1660	2010	2440	2770	3150	3520	3850	4470	
	20	15	0	0	0	170	280	450	570	690	850	1050	1290	1570	1900	2160	2470	2770	3030	3540	
	25	18.5	0	0	0	140	220	360	450	550	690	850	1050	1260	1540	1750	1990	2250	2460	2850	
	30	22	0	0	0	0	180	294	370	460	570	700	870	1050	1270	1450	1660	1870	2040	2380	
230V 60Hz Three Phase 6 - Lead Y-D	5	3.7	210	340	550	880	1380	2140	2680	3280	4030	4930	6040	7270	8800	9970					
	7 1/2	5.5	150	240	390	630	970	1530	1900	2340	2880	3510	4300	5160	6240	7060	8010	8950	9750		
	10	7.5	110	180	280	460	730	1140	1420	1750	2160	2640	3240	3910	4740	5380	6150	6900	7530	8760	
	15	11	0	0	190	310	490	780	970	1200	1470	1800	2200	2670	3220	3660	4170	4660	5100	5910	
	20	15	0	0	140	230	370	600	750	910	1140	1390	1710	2070	2520	2860	3270	3670	4020	4680	
	25	18.5	0	0	0	190	300	480	600	750	910	1120	1380	1680	2040	2310	2640	2970	3240	3780	
	30	22	0	0	0	150	240	390	490	610	760	930	1140	1390	1690	1920	2200	2470	2700	3160	
380V 60Hz Three Phase 6 - Lead Y-D	5	3.7	600	960	1510	2380	3730	5800	7170	8800											
	7 1/2	5.5	400	660	1030	1630	2560	3960	4890	6000	7390	9010									
	10	7.5	300	480	760	1200	1870	2890	3570	4360	5350	6490	7840	9390							
	15	11	210	340	550	880	1380	2140	2650	3250	4030	4930	6000	7260	8650	9780					
	20	15	160	260	410	660	1050	1630	2020	2500	3090	3790	4630	5640	6750	7660	4260	9760			
	25	18.5	0	210	330	540	850	1320	1650	2020	2500	3070	3760	4560	5460	6190	7080	7870	8610	9880	
	30	22	0	0	270	430	700	1090	1360	1680	2070	2550	3120	3780	4530	5140	5880	6540	7150	8230	
	40	30	0	0	0	320	510	790	990	1230	1510	1860	2280	2760	3300	3750	4270	4750	5200	5980	
	50	37	0	0	0	250	400	630	810	990	1230	1500	1830	2220	2650	3010	3430	3820	4170	4780	
	60	45	0	0	0	0	340	540	660	840	1030	1270	1540	1870	2250	2550	2910	3220	3520	4050	
	75	55	0	0	0	0	0	450	550	690	850	1050	1290	1570	1900	2160	2490	2770	3040	3520	
	100	75	0	0	0	0	0	0	420	520	640	760	940	1140	1360	1540	1770	1960	2140	2470	
	125	90	0	0	0	0	0	0	0	400	490	600	730	930	1110	1260	1420	1590	1740	1990	
	150	110	0	0	0	0	0	0	0	0	420	510	620	750	930	1050	1180	1320	1440	1630	
	175	130	0	0	0	0	0	0	0	0	360	440	540	660	780	970	1120	1260	1380	1600	
	200	150	0	0	0	0	0	0	0	0	0	0	480	580	690	790	940	1050	1140	1320	
460V 60Hz Three Phase 6 - Lead Y-D	5	3.7	880	1420	2250	3540	5550	8620													
	7 1/2	5.5	630	1020	1600	2530	3960	6150	7650	9390											
	10	7.5	460	750	1180	1870	2940	4570	5700	7020	8620										
	15	11	310	510	810	1270	2010	3130	3900	4800	5890	7210	8850								
	20	15	230	380	610	970	1540	2410	3000	3700	4560	5590	6870	8290							
	25	18.5	190	310	490	790	1240	1950	2430	2980	3670	4510	5550	6700	8140						
	30	22	0	250	410	640	1020	1600	1990	2460	3040	3730	4590	5550	6750	7690	8790				
	40	30	0	0	300	480	750	1180	1470	1810	2230	2740	3370	4060	4930	5590	6370				
	50	37	0	0	0	370	590	960	1200	1470	1810	2220	2710	3280	3970	4510	5130	5740	6270	7270	
	60	45	0	0	0	320	500	810	1000	1240	1530	1870	2310	2770	3360	3810	4330	4860	5310	6150	
	75	55	0	0	0	0	420	660	810	1020	1260	1540	1890	2280	2770	3150	3600	4050	4420	5160	
	100	75	0	0	0	0	0	500	610	760	930	1140	1410	1690	2070	2340	2680	3010	3280	3820	
	125	90	0	0	0	0	0	0	470	590	730	880	1110	1330	1500	1830	2080	2340	2550	2940	
	150	110	0	0	0	0	0	0	0	510	630	770	950	1140	1380	1570	1790	2000	2180	2530	
	175	130	0	0	0	0	0	0	0	0	550	680	830	1000	1220	1390	1580	1780	1950	2270	
	200	150	0	0	0	0	0	0	0	0	0	590	730	880	1070	1210	1380	1550	1690	1970	
575V 60Hz Three Phase 6 - Lead Y-D	5	3.7	1380	2220	3490	5520	8620														
	7 1/2	5.5	990	1590	2520	3970	6220														
	10	7.5	730	1170	1860	2920	4590	7150	8910												
	15	11	490	790	1270	2010	3130	4890	6090												
	20	15	370	610	970	1540	2410	3780	4710	5790	7140	8740									
	25	18.5	300	490	780	1240	1950	3040	3790	4660	5760	7060									
	30	22	240	400	645	1020	1600	2500	3120	3840	4740	5820	7150	8670							
	40	30	0	300	480	750	1180	1860	2310	2850	3490	4290	5260	6340	7710	8740					
	50	37	0	0	380	590	960	1500	1870	2310	2830	3460	4260	5130	6210	7050	8010	8980	9790		
	60	45	0	0	0	500	790	1270	1590	1950	2400	2940	3600	4330	5250	5950	6780	7600	8290	9610	
	75	55	0	0	0	0	420	660	1030	1290	1590	1960	2400	2950	3570	4330	4930	5620	6330	6910	8050
	100	75	0	0	0	0	0	400	780	960	1180	1450	1780	2190	2650	3220	3660	4180	4710	5140	5980
	125	90	0	0	0	0	0	0	600	740	920	1150	1420	1740	2100	2530	2880	3270	3660	3970	4600
	150	110	0	0	0	0	0	0	0	650	800	990	1210	1480	1780	2160	2450	2790	3120	3410	3950
	175	130	0	0	0	0	0	0	0	0	700	860	1060	1300	1570	1910	2170	2480	2780	3040	3540
	200	150	0	0	0	0	0	0	0	0	0	760	930	1140	1370	1670	1890	2160	2420	2640	3070

See Footnotes on Page 11 for information on bold figures.



Application - Three Phase Motors

Table 18 Three Phase 75°C Cable, 60 Hz (Service Entrance to Motor) Maximum Length in Feet

Motor Rating			75°C Insulation - AWG Copper Wire Size													MCM Copper Wire Size						
Volts	HP	KW	14	12	10	8	6	4	3	2	1	0	00	000	0000	250	300	350	400	500		
200 v 60Hz Three Phase 3 - Lead	1/2	0.37	710	1140	1800	2840	4420															
	3/4	0.55	510	810	1280	2030	3160															
	1	0.75	430	690	1080	1710	2670	4140	5140													
	1 1/2	1.1	310	500	790	1260	1960	3050	3780													
	2	1.5	240	390	610	970	1520	2360	2940	3610	4430	5420										
	3	2.2	180	290	470	740	1160	1810	2250	2760	3390	4130										
	5	3.7	110	170	280	440	690	1080	1350	1660	2040	2490	3050	3670	4440	5030						
	7 1/2	5.5	0	0	200	310	490	770	960	1180	1450	1770	2170	2600	3150	3560						
	10	7.5	0	0	150	230	370	570	720	880	1090	1330	1640	1970	2390	2720	3100	3480	3800	4420		
	15	11	0	0	0	160	250	390	490	600	740	910	1110	1340	1630	1850	2100	2350	2570	2980		
	20	15	0	0	0	0	190	300	380	460	570	700	860	1050	1270	1440	1650	1850	2020	2360		
	25	18.5	0	0	0	0	0	240	300	370	460	570	700	840	1030	1170	1330	1500	1640	1900		
30	22	0	0	0	0	0	200	250	310	380	470	580	700	850	970	1110	1250	1360	1590			
230V 60 Hz Three Phase 3 - Lead	1/2	0.37	930	1490	2350	3700	5760	8910														
	3/4	0.55	670	1080	1700	2580	4190	6490	8060	9860												
	1	0.75	560	910	1430	2260	3520	5460	6780	8290												
	1 1/2	1.1	420	670	1060	1670	2610	4050	5030	6160	7530	9170										
	2	1.5	320	510	810	1280	2010	3130	3890	4770	5860	7170	8780									
	3	2.2	240	390	620	990	1540	2400	2980	3660	4480	5470	6690	8020	9680							
	5	3.7	140	230	370	590	920	1430	1790	2190	2690	3290	4030	4850	5870	6650	7560	8460	9220			
	7 1/2	5.5	0	160	260	420	650	1020	1270	1560	1920	2340	2870	3440	4160	4710	5340	5970	6500	7510		
	10	7.5	0	0	190	310	490	760	950	1170	1440	1760	2160	2610	3160	3590	4100	4600	5020	5840		
	15	11	0	0	0	210	330	520	650	800	980	1200	1470	1780	2150	2440	2780	3110	3400	3940		
	20	15	0	0	0	160	250	400	500	610	760	930	1140	1380	1680	1910	2180	2450	2680	3120		
	25	18.5	0	0	0	0	200	320	400	500	610	750	920	1120	1360	1540	1760	1980	2160	2520		
30	22	0	0	0	0	0	260	330	410	510	620	760	930	1130	1280	1470	1650	1800	2110			
380V 60 Hz Three Phase 3 - Lead	1/2	0.37	2690	4290	6730																	
	3/4	0.55	2000	3190	5010	7860																
	1	0.75	1620	2580	4060	6390	9980															
	1 1/2	1.1	1230	1970	3100	4890	7630															
	2	1.5	870	1390	2180	3450	5400	8380														
	3	2.2	680	1090	1710	2690	4200	6500	8020	9830												
	5	3.7	400	640	1010	1590	2490	3870	4780	5870	7230	8830										
	7 1/2	5.5	270	440	690	1090	1710	2640	3260	4000	4930	6010	7290	8780								
	10	7.5	200	320	510	800	1250	1930	2380	2910	3570	4330	5230	6260	7390	8280	9340					
	15	11	0	0	370	590	920	1430	1770	2170	2690	3290	4000	4840	5770	6520	7430	8250	8990			
	20	15	0	0	280	440	700	1090	1350	1670	2060	2530	3090	3760	4500	5110	5840	6510	7120	8190		
	25	18.5	0	0	0	360	570	880	1100	1350	1670	2050	2510	3040	3640	4130	4720	5250	5740	6590		
	30	22	0	0	0	290	470	730	910	1120	1380	1700	2080	2520	3020	3430	3920	4360	4770	5490		
	40	30	0	0	0	0	0	530	660	820	1010	1240	1520	1840	2200	2500	2850	3170	3470	3990		
	50	37	0	0	0	0	0	440	540	660	820	1000	1220	1480	1770	2010	2290	2550	2780	3190		
	60	45	0	0	0	0	0	370	460	560	690	850	1030	1250	1500	1700	1940	2150	2350	2700		
	75	55	0	0	0	0	0	0	0	460	570	700	860	1050	1270	1440	1660	1850	2030	2350		
	100	75	0	0	0	0	0	0	0	0	420	510	630	760	910	1030	1180	1310	1430	1650		
125	90	0	0	0	0	0	0	0	0	0	0	510	620	740	840	950	1060	1160	1330			
150	110	0	0	0	0	0	0	0	0	0	0	0	520	620	700	790	880	960	1090			
175	130	0	0	0	0	0	0	0	0	0	0	0	0	560	650	750	840	920	1070			
200	150	0	0	0	0	0	0	0	0	0	0	0	0	0	550	630	700	760	880			

Continued on page 19



Application - Three Phase Motors

Table 19 Three Phase 75°C Cable (Continued)

Motor Rating			75°C Insulation - AWG Copper Wire Size													MCM Copper Wire Size					
Volts	HP	KW	14	12	10	8	6	4	3	2	1	0	00	000	0000	250	300	350	400	500	
460V 60Hz Three Phase 3 - Lead	1/2	0.37	3770	6020	9460																
	3/4	0.55	2730	4350	6850																
	1	0.75	2300	3670	5770	9070															
	1 1/2	1.1	1700	2710	4270	6730															
	2	1.5	1300	2070	3270	5150	8050														
	3	2.2	1000	1600	2520	3970	6200														
	5	3.7	590	950	1500	2360	3700	5750													
	7 1/2	5.5	420	680	1070	1690	2640	4100	5100	6260	7680										
	10	7.5	310	500	790	1250	1960	3050	3800	4680	5750	7050									
	15	11	0	340	540	850	1340	2090	2600	3200	3930	4810	5900	7110							
	20	15	0	0	410	650	1030	1610	2000	2470	3040	3730	4580	5530							
	25	18.5	0	0	330	530	830	1300	1620	1990	2450	3010	3700	4470	5430						
	30	22	0	0	270	430	680	1070	1330	1640	2030	2490	3060	3700	4500	5130	5860				
	40	30	0	0	0	320	500	790	980	1210	1490	1830	2250	2710	3290	3730	4250				
	50	37	0	0	0	0	410	640	800	980	1210	1480	1810	2190	2650	3010	3420	3830	4180	4850	
	60	45	0	0	0	0	0	540	670	830	1020	1250	1540	1850	2240	2540	2890	3240	3540	4100	
	75	55	0	0	0	0	0	440	550	680	840	1030	1260	1520	1850	2100	2400	2700	2950	3440	
	100	75	0	0	0	0	0	0	0	500	620	760	940	1130	1380	1560	1790	2010	2190	2550	
	125	90	0	0	0	0	0	0	0	0	0	600	740	890	1000	1220	1390	1560	1700	1960	
	150	110	0	0	0	0	0	0	0	0	0	0	630	760	920	1050	1190	1340	1460	1690	
175	130	0	0	0	0	0	0	0	0	0	0	0	370	810	930	1060	1190	1300	1510		
200	150	0	0	0	0	0	0	0	0	0	0	0	590	710	810	920	1030	1130	1310		
575V 60 Hz Three Phase 3 - Lead	1/2	0.37	5900	9410																	
	3/4	0.55	4270	6810																	
	1	0.75	3630	5800	9120																
	1 1/2	1.1	2620	4180	6580																
	2	1.5	2030	3250	5110	8060															
	3	2.2	1580	2530	3980	6270															
	5	3.7	920	1480	2330	3680	5750														
	7 1/2	5.5	660	1060	1680	2650	4150														
	10	7.5	490	780	1240	1950	3060	4770	5940												
	15	11	330	530	850	1340	2090	3260	4060												
	20	15	0	410	650	1030	1610	2520	3140	3860	4760	5830									
	25	19	0	0	520	830	1300	2030	2530	3110	3840	4710									
	30	22	0	0	430	680	1070	1670	2080	2560	3160	3880	4770	5780	7030	8000					
	40	30	0	0	0	500	790	1240	1540	1900	2330	2860	3510	4230	5140	5830					
	50	37	0	0	0	410	640	1000	1250	1540	1890	2310	2840	3420	4140	4700	5340	5990	6530	7580	
	60	45	0	0	0	0	540	850	1060	1300	1600	1960	2400	2890	3500	3970	4520	5070	5530	6410	
	75	55	0	0	0	0	0	690	860	1060	1310	1600	1970	2380	2890	3290	3750	5220	4610	5370	
	100	75	0	0	0	0	0	0	640	790	970	1190	1460	1770	2150	2440	2790	3140	3430	3990	
	125	90	0	0	0	0	0	0	0	630	770	950	1160	1400	1690	1920	2180	2440	2650	3070	
	150	110	0	0	0	0	0	0	0	0	660	800	990	1190	1440	1630	1860	2080	2270	2640	
175	130	0	0	0	0	0	0	0	0	0	700	870	1050	1270	1450	1650	1860	2030	2360		
200	150	0	0	0	0	0	0	0	0	0	0	760	920	1110	1260	1440	1620	1760	2050		

See Footnotes on Page 11 for information on bold figures.



Application - Three Phase Motors

Table 20 Three Phase 75°C Cable (Continued)

Motor Rating			75°C Insulation - AWG Copper Wire Size													MCM Copper Wire Size					
Volts	HP	KW	14	12	10	8	6	4	3	2	1	0	00	000	0000	250	300	350	400	500	
200V 60Hz	5	3.7	160	250	420	660	1030	1620	2020	2490	3060	3730	4570	5500	6660	7540					
	7 1/2	5.5	110	180	300	460	730	1150	1440	1770	2170	2650	3250	3900	4720	5340					
Three Phase	10	7.5	80	130	210	340	550	850	1080	1320	1630	1990	2460	2950	3580	4080	4650	5220	5700	6630	
	15	11	0	0	140	240	370	580	730	900	1110	1360	1660	2010	2440	2770	3150	3520	3850	4470	
6 - Lead Y-D	20	15	0	0	120	170	280	450	570	690	850	1050	1290	1570	1900	2160	2470	2770	3030	3540	
	25	18.5	0	0	0	140	220	360	450	550	690	850	1050	1260	1540	1750	1990	2250	2460	2850	
	30	22	0	0	0	120	180	294	370	460	570	700	870	1050	1270	1450	1660	1870	2040	2380	
230V 60Hz	5	3.7	210	340	550	880	1380	2140	2680	3280	4030	4930	6040	7270	8800	9970					
	7 1/2	5.5	150	240	390	630	970	1530	1900	2340	2880	3510	4300	5160	6240	7060	8010	8950	9750		
Three Phase	10	7.5	110	180	280	460	730	1140	1420	1750	2160	2640	3240	3910	4740	5380	6150	6900	7530	8760	
	15	11	0	130	190	310	490	780	970	1200	1470	1800	2200	2670	3220	3660	4170	4660	5100	5910	
6 - Lead Y-D	20	15	0	0	140	230	370	600	750	910	1140	1390	1710	2070	2520	2860	3270	3670	4020	4680	
	25	18.5	0	0	120	190	300	480	600	750	910	1120	1380	1680	2040	2310	2640	2970	3240	3780	
	30	22	0	0	0	150	240	390	490	610	760	930	1140	1390	1690	1920	2200	2470	2700	3160	
380V 60Hz	5	3.7	600	960	1510	2380	3730	5800	7170	8800											
	7 1/2	5.5	400	660	1030	1630	2560	3960	4890	6000	7390	9010									
Three Phase	10	7.5	300	480	760	1200	1870	2890	3570	4360	5350	6490	7840	9390							
	15	11	210	340	550	880	1380	2140	2650	3250	4030	4930	6000	7260	8650	9780					
6 - Lead Y-D	20	15	160	260	410	660	1050	1630	2020	2500	3090	3790	4630	5640	6750	7660	4260	9760			
	25	18.5	0	210	330	540	850	1320	1650	2020	2500	3070	3760	4560	5460	6190	7080	7870	8610	9880	
	30	22	0	0	270	430	700	1090	1360	1680	2070	2550	3120	3780	4530	5140	5880	6540	7150	8230	
	40	30	0	0	210	320	510	790	990	1230	1510	1860	2280	2760	3300	3750	4270	4750	5200	5980	
	50	37	0	0	0	250	400	630	810	990	1230	1500	1830	2220	2650	3010	3430	3820	4170	4780	
	60	45	0	0	0	0	340	540	660	840	1030	1270	1540	1870	2250	2550	2910	3220	3520	4050	
	75	55	0	0	0	0	290	450	550	690	850	1050	1290	1570	1900	2160	2490	2770	3040	3520	
	100	75	0	0	0	0	0	340	420	520	640	760	940	1140	1360	1540	1770	1960	2140	2470	
	125	90	0	0	0	0	0	0	340	400	490	600	730	930	1110	1260	1420	1590	1740	1990	
	150	110	0	0	0	0	0	0	0	350	420	510	620	750	930	1050	1180	1320	1440	1630	
	175	130	0	0	0	0	0	0	0	0	360	440	540	660	780	970	1120	1260	1380	1600	
	200	150	0	0	0	0	0	0	0	0	0	410	480	580	690	790	940	1050	1140	1320	
460V 60Hz	5	3.7	880	1420	2250	3540	5550	8620													
	7 1/2	5.5	630	1020	1600	2530	3960	6150	7650	9390											
Three Phase	10	7.5	460	750	1180	1870	2940	4570	5700	7020	8620										
	15	11	310	510	810	1270	2010	3130	3900	4800	5890	7210	8850								
6 - Lead Y-D	20	15	230	380	610	970	1540	2410	3000	3700	4560	5590	6870	8290							
	25	18.5	190	310	490	790	1240	1950	2430	2980	3670	4510	5550	6700	8140						
	30	22	0	250	410	640	1020	1600	1990	2460	3040	3730	4590	5550	6750	7690	8790				
	40	30	0	0	300	480	750	1180	1470	1810	2230	2740	3370	4060	4930	5590	6370				
	50	37	0	0	250	370	590	960	1200	1470	1810	2220	2710	3280	3970	4510	5130	5740	6270	7270	
	60	45	0	0	0	320	500	810	1000	1240	1530	1870	2310	2770	3360	3810	4330	4860	5310	6150	
	75	55	0	0	0	0	420	660	810	1020	1260	1540	1890	2280	2770	3150	3600	4050	4420	5160	
	100	75	0	0	0	0	310	500	610	760	930	1140	1410	1690	2070	2340	2680	3010	3280	3820	
	125	90	0	0	0	0	0	390	470	590	730	880	1110	1330	1500	1830	2080	2340	2550	2940	
	150	110	0	0	0	0	0	0	420	510	630	770	950	1140	1380	1570	1790	2000	2180	2530	
	175	130	0	0	0	0	0	0	0	450	550	680	830	1000	1220	1390	1580	1780	1950	2270	
	200	150	0	0	0	0	0	0	0	0	480	590	730	880	1070	1210	1380	1550	1690	1970	
575V 60Hz	5	3.7	1380	2220	3490	5520	8620														
	7 1/2	5.5	990	1590	2520	3970	6220														
Three Phase	10	7.5	730	1170	1860	2920	4590	7150	8910												
	15	11	490	790	1270	2010	3130	4890	6090												
6 - Lead Y-D	20	15	370	610	970	1540	2410	3780	4710	5790	7140	8740									
	25	18.5	300	490	780	1240	1950	3040	3790	4660	5760	7060									
	30	22	240	400	645	1020	1600	2500	3120	3840	4740	5820	7150	8670							
	40	30	0	300	480	750	1180	1860	2310	2850	3490	4290	5260	6340	7710	8740					
	50	37	0	0	380	590	960	1500	1870	2310	2830	3460	4260	5130	6210	7050	8010	8980	9790		
	60	45	0	0	330	500	790	1270	1590	1950	2400	2940	3600	4330	5250	5950	6780	7600	8290	9610	
	75	55	0	0	0	420	660	1030	1290	1590	1960	2400	2950	3570	4330	4930	5620	6330	6910	8050	
	100	75	0	0	0	0	400	780	960	1180	1450	1780	2190	2650	3220	3660	4180	4710	5140	5980	
	125	90	0	0	0	0	0	600	740	920	1150	1420	1740	2100	2530	2880	3270	3660	3970	4600	
	150	110	0	0	0	0	0	520	650	800	990	1210	1480	1780	2160	2450	2790	3120	3410	3950	
	175	130	0	0	0	0	0	0	570	700	860	1060	1300	1570	1910	2170	2480	2780	3040	3540	
	200	150	0	0	0	0	0	0	500	610	760	930	1140	1370	1670	1890	2160	2420	2640	3070	

See Footnotes on Page 11 for information on bold figures.



Application - Three Phase Motors

Table 21 Three Phase Motor Specifications (60 Hz)

Type	Motor Model Prefix	Rating					Full Load Amps	Maximum (S.F. Load) Amps	Line to Line Resistance Ohms	Efficiency %			Locked Rotor Amps	KVA Code	Circuit Breakers or Fuse Amps		
		HP	KW	Volts	Hz	S.F.				S.F.	F.L.	3/4			Nontime Delay (Std.) Fuse	Dual Element Time Delay Fuse	Inverse Time Breaker
4 Inch	234501	1/2	0.37	200	60	1.60	2.8	3.4	6.6-7.3	70	64	58	17.5	N	10	5	8
	234511	1/2	0.37	230	60	1.60	2.4	2.9	9.5-10.4	70	64	58	15.2	N	8	5	6
	234541	1/2	0.37	380	60	1.60	1.5	1.8	23.2-23.4	70	64	58	9.2	N	5	3	4
	234521	1/2	0.37	460	60	1.60	1.2	1.5	38.4-41.6	70	64	58	7.6	N	4	3	3
	234502	3/4	0.55	200	60	1.50	3.7	4.4	4.6-5.1	73	69	65	23.1	M	15	8	10
	234512	3/4	0.55	230	60	1.50	3.2	3.8	7.2-7.8	73	69	65	20.1	M	10	6	8
	234542	3/4	0.55	380	60	1.50	1.9	2.3	16.6-20.3	73	69	65	12.2	M	6	4	5
	234522	3/4	0.55	460	60	1.50	1.6	1.9	27.8-30.2	73	69	65	10.7	M	5	3	4
	234503	1	0.75	200	60	1.40	4.6	5.4	4.1-4.5	72	70	66	30.9	M	15	10	15
	234513	1	0.75	230	60	1.40	4.0	4.7	5.2-5.6	72	70	66	26.9	M	15	8	10
	234543	1	0.75	380	60	1.40	2.4	2.8	12.2-14.9	72	70	66	16.3	M	8	5	8
	234523	1	0.75	460	60	1.40	2.0	2.4	21.2-23.0	72	70	66	13.5	M	6	4	5
	234504	1 1/2	1.1	200	60	1.30	5.6	6.8	2.5-3.0	76	76	74	38.2	K	20	10	15
	234514	1 1/2	1.1	230	60	1.30	4.9	5.9	3.2-4.0	76	76	74	33.2	K	15	10	15
	234544	1 1/2	1.1	380	60	1.30	3.0	3.6	8.5-10.4	76	76	74	20.1	K	10	6	8
	234524	1 1/2	1.1	460	60	1.30	2.5	3.0	13.0-16.0	76	76	74	16.6	K	8	5	8
	234534	1 1/2	1.1	575	60	1.30	2.0	2.4	20.3-25.0	76	76	74	13.3	K	6	4	5
	234305	2	1.5	200	60	1.25	7.9	9.3	1.9-2.4	69	69	67	53.6	L	25	15	20
	234315	2	1.5	230	60	1.25	6.9	8.1	2.4-3.0	69	69	67	46.6	L	25	15	20
	234345	2	1.5	380	60	1.25	4.2	4.9	6.6-8.2	69	69	67	28.2	L	15	8	15
	234325	2	1.5	460	60	1.25	3.5	4.1	9.7-12.0	69	69	67	23.3	L	15	8	10
	234335	2	1.5	575	60	1.25	2.8	3.2	15.1-18.7	69	69	67	18.6	L	10	5	8
	234306	3	2.2	200	60	1.15	11.3	12.4	1.3-1.7	75	75	73	71.2	K	35	20	30
	234316	3	2.2	230	60	1.15	9.8	10.8	1.8-2.2	75	75	73	61.9	K	30	20	25
	234346	3	2.2	380	60	1.15	5.9	6.5	4.7-6.0	75	75	73	37.5	K	20	15	15
	234326	3	2.2	460	60	1.15	4.9	5.4	7.0-8.7	75	75	73	31.0	K	15	10	15
	234336	3	2.2	575	60	1.15	3.9	4.3	10.9-13.6	75	75	73	24.8	K	15	8	10
	234307	5	3.7	200	60	1.15	18.4	20.4	.70-.94	74	74	72	122.0	K	60	35	50
	234317	5	3.7	230	60	1.15	16.0	17.7	.93-1.2	74	74	72	106.0	K	50	30	40
	234347	5	3.7	380	60	1.15	9.7	10.7	2.4-3.0	74	74	72	64.4	K	30	20	25
	234327	5	3.7	460	60	1.15	8.0	8.9	3.6-4.4	74	74	72	53.2	K	25	15	20
	234337	5	3.7	575	60	1.15	6.4	7.1	5.6-6.9	74	74	72	42.6	K	20	15	20
	234308	7 1/2	5.5	200	60	1.15	27.1	29.9	.46-.57	76	76	74	188.0	K	90	50	70
	234318	7 1/2	5.5	230	60	1.15	23.6	26.0	.61-.75	76	76	74	164.0	K	80	45	60
	234348	7 1/2	5.5	380	60	1.15	14.3	15.7	1.6-2.3	76	76	74	99.1	K	45	25	40
	234328	7 1/2	5.5	460	60	1.15	11.8	13.0	2.4-3.4	76	76	74	81.9	K	40	25	30
	234338	7 1/2	5.5	575	60	1.15	9.4	10.4	3.5-5.1	76	76	74	65.5	K	30	20	25
	234349	10	7.5	380	60	1.15	20.6	22.4	1.2-1.6	75	75	72	140.0	L	70	40	60
	234329	10	7.5	460	60	1.15	17.0	18.5	1.8-2.3	75	75	72	116.0	L	60	30	45
234339	10	7.5	575	60	1.15	13.6	14.8	2.8-3.5	75	75	72	92.8	L	45	25	35	



Application - Three Phase Motors

Table 22 Three Phase Motor Specifications (60 Hz)

Type	Motor Model Prefix	Rating					Full Load Amps	Maximum (S.F. Load) Amps	Line to Line Resistance Ohms	Efficiency %			Locked Rotor Amps	KVA Code	Circuit Breakers or Fuse Amps		
		HP	KW	Volts	Hz	S.F.				S.F.	F.L.	3/4			Nontime Delay (Std.) Fuse	Dual Element Time Delay Fuse	Inverse Time Breaker
6 Inch	236650	5	3.7	200	60	1.15	17.5	19.1	.68-.84	79	79	77	99	H	60	35	45
	236600	5	3.7	230	60	1.15	15	16.6	.88-1.09	79	79	77	86	H	45	30	40
	236660	5	3.7	380	60	1.15	9.1	10	2.4-3.0	79	79	77	52	H	30	20	25
	236610	5	3.7	460	60	1.15	7.5	8.8	3.5-4.0	79	79	77	43	H	25	15	20
	236620	5	3.7	575	60	1.15	6	6.6	5.9-7.2	79	79	77	34	H	20	15	15
	236651	7 1/2	5.5	200	60	1.15	25.1	28.3	.39-.48	80	80	78	150	H	80	45	70
	236601	7 1/2	5.5	230	60	1.15	21.8	24.6	.57-.71	80	80	78	130	H	70	40	60
	236661	7 1/2	5.5	380	60	1.15	13.2	14.9	1.5-1.8	80	80	78	79	H	45	25	35
	236611	7 1/2	5.5	460	60	1.15	10.9	12.3	2.2-2.7	80	80	78	65	H	35	20	30
	236621	7 1/2	5.5	575	60	1.15	8.7	9.8	3.6-4.4	80	80	78	52	H	30	20	25
	236652	10	7.5	200	60	1.15	32.7	37	.33-.42	79	79	78	198	H	100	60	90
	236602	10	7.5	230	60	1.15	28.4	32.2	.44-.55	79	79	78	172	H	90	60	80
	236662	10	7.5	380	60	1.15	17.2	19.5	1.2-1.5	79	79	78	104	H	60	35	45
	236612	10	7.5	460	60	1.15	14.2	16.1	1.7-2.2	79	79	78	86	H	45	30	40
	236622	10	7.5	575	60	1.15	11.4	12.9	2.8-3.5	79	79	78	69	H	35	25	30
	236653	15	11	200	60	1.15	47.8	54.5	.22-.27	81	81	80	306	H	150	90	125
	236603	15	11	230	60	1.15	41.6	47.4	.27-.33	81	81	80	266	H	150	80	110
	236663	15	11	380	60	1.15	25.2	28.7	.73-.90	81	81	80	161	H	80	45	70
	236613	15	11	460	60	1.15	20.8	23.7	1.1-1.3	81	81	80	133	H	70	40	60
	236623	15	11	575	60	1.15	16.7	19	1.7-2.1	81	81	80	106	H	60	30	45
	236654	20	15	200	60	1.15	61.9	69.7	.14-.17	82	82	81	416	J	200	110	175
	236604	20	15	230	60	1.15	53.8	60.6	.20-.25	82	82	81	362	J	175	100	150
	236664	20	15	380	60	1.15	32.6	36.7	.52-.64	82	82	81	219	J	100	60	90
	236614	20	15	460	60	1.15	26.9	30.3	.76-.94	82	82	81	181	J	90	50	70
	236624	20	15	575	60	1.15	21.5	24.4	1.2-1.5	82	82	81	145	J	70	40	60
	236655	25	18.5	200	60	1.15	77.1	86.3	.11-.14	83	83	82	552	J	250	150	200
	236605	25	18.5	230	60	1.15	67	75	.15-.19	83	83	82	480	J	225	125	175
	236665	25	18.5	380	60	1.15	40.6	45.4	.40-.50	83	83	82	291	J	125	80	110
	236615	25	18.5	460	60	1.15	33.5	37.5	.59-.73	83	83	82	240	J	110	60	90
	236625	25	18.5	575	60	1.15	26.8	30	1.0-1.3	83	83	82	192	J	90	50	70
236656	30	22	200	60	1.15	90.9	104	.10-.12	83	83	86	653	J	300	175	250	
236606	30	22	230	60	1.15	79	90.4	.12-.15	83	83	86	568	J	250	150	225	
236666	30	22	380	60	1.15	47.8	54.7	.33-.41	83	83	86	317	J	150	90	125	
236616	30	22	460	60	1.15	39.5	45.2	.48-.60	83	83	86	284	J	125	80	110	
236626	30	22	575	60	1.15	31.6	36.2	.78-.95	83	83	86	227	J	100	60	90	
236667	40	30	380	60	1.15	64.8	75	.20-.27	83	83	83	481	J	200	125	175	
236617	40	30	460	60	1.15	53.5	62	.32-.40	83	83	83	397	J	175	100	150	
236627	40	30	575	60	1.15	42.8	49.6	.53-.59	83	83	83	318	H	150	80	110	
236668	50	37	380	60	1.15	82	93.2	.17-.22	82	83	83	501	H	250	150	225	
236618	50	37	460	60	1.15	67.7	77	.25-.32	82	83	83	414	H	225	125	175	
236628	50	37	575	60	1.15	54.2	61.6	.39-.48	82	83	83	331	H	175	100	150	
236669	60	45	380	60	1.15	97.4	110.2	.15-.18	84	84	84	627	H	300	175	250	
236619	60	45	460	60	1.15	80.5	91	.22-.27	84	84	84	518	H	250	150	225	
236629	60	45	575	60	1.15	64.4	72.8	.35-.39	84	84	84	414	H	200	125	175	

Model numbers are three lead motors. Six lead motors with different model numbers have the same running performance, but when wye connected for starting have locked rotor amps 33% of the values shown.



Application - Three Phase Motors

Table 23 Three Phase Motor Specifications (60 Hz)

Type	Motor Model Prefix	Rating					Full Load Amps	Maximum (S.F. Load) Amps	Line to Line Resistance Ohms	Efficiency %			Locked Rotor Amps	KVA Code	Circuit Breakers or Fuse Amps		
		HP	KW	Volts	Hz	S.F.				S.F.	F.L.	3/4			Nontime Delay (Std.) Fuse	Dual Element Time Delay Fuse	Inverse Time Breaker
8 Inch	239660	40	30	380	60	1.15	64	72	.162-.198	86	86	85	479	J	200	125	175
	239600	40	30	460	60	1.15	53	60	.247-.303	86	86	85	396	J	175	100	150
	239610	40	30	575	60	1.15	42	48	.399-.487	86	86	85	317	J	150	80	110
	239661	50	37	380	60	1.15	77	88	.127-.156	87	87	86	656	K	250	150	200
	239601	50	37	460	60	1.15	64	73	.181-.221	87	87	86	542	K	200	125	175
	239611	50	37	575	60	1.15	51	59	.280-.342	87	87	86	434	K	175	90	150
	239662	60	45	380	60	1.15	92	104	.090-.110	88	87	86	797	K	300	175	250
	239602	60	45	460	60	1.15	76	86	.142-.174	88	87	86	658	K	250	150	200
	239612	60	45	575	60	1.15	61	69	.227-.277	88	87	86	526	K	200	110	175
	239663	75	55	380	60	1.15	114	130	.069-.085	88	88	87	1046	L	350	200	300
	239603	75	55	460	60	1.15	94	107	.106-.130	88	88	87	864	L	300	175	250
	239613	75	55	575	60	1.15	76	86	.169-.207	88	88	87	691	L	250	150	200
	239664	100	75	380	60	1.15	153	172	.051-.062	89	89	88	1466	L	500	300	400
	239604	100	75	460	60	1.15	126	142	.073-.089	89	89	88	1211	L	400	225	350
	239614	100	75	575	60	1.15	101	114	.110-.134	89	89	88	969	L	350	200	300
	239165	125	90	380	60	1.15	202	228	.032-.042	87	86	85	1596	K	700	400	600
	239105	125	90	460	60	1.15	167	188	.055-.067	87	86	85	1318	K	500	300	450
	239115	125	90	575	60	1.15	134	151	.087-.106	87	86	85	1054	K	450	250	350
	239166	150	110	380	60	1.15	235	266	.028-.034	88	87	86	1961	K	800	450	600
	239106	150	110	460	60	1.15	194	219	.042-.051	88	87	86	1620	K	600	350	500
	239116	150	110	575	60	1.15	155	176	.067-.082	88	87	86	1296	K	500	300	400
	239167	175	130	380	60	1.15	265	302	.028-.035	88	88	87	1991	J	800	500	700
	239107	175	130	460	60	1.15	219	249	.042-.052	88	88	87	1645	J	700	400	600
	239117	175	130	575	60	1.15	175	200	.063-.077	88	88	87	1316	J	600	350	450
	239168	200	150	380	60	1.15	298	342	.024-.029	88	88	87	2270	J	1000	600	800
	239108	200	150	460	60	1.15	246	282	.036-.044	88	88	87	1875	J	800	450	700
	239118	200	150	575	60	1.15	197	226	.057-.070	88	88	87	1500	J	600	350	500

Model numbers are three lead motors. Six lead motors with different model numbers have the same running performance, but when wye connected for starting have locked rotor amps 33% of the values shown.



Application - Three Phase Motors

Overload Protection Of Three Phase Submersible Motors - Class 10 Protection Required

The characteristics of submersible motors are different from standard motors and special overload protection is required.

If the motor is stalled, the overload protector must trip within 10 seconds to protect the motor windings. The installer must use SUBTROL or the quick-trip protection shown in these tables. All recommended overload selections are of the ambient compensated type to maintain protection at high and low air temperatures.

All heaters and amp settings shown are based on total line amps. When a six-lead motor is used with a Wye-Delta starter, divide motor amps by 1.732 to make your selection or adjustment for heaters carrying phase amps.

Tables 24, 25 and 26 list the correct selection and settings for several manufacturers. Approval of other types may be requested.

Refer to notes on Page 25.

Table 24 60 Hz 4" Motors

HP	KW	Volts	NEMA Starter Size	Heaters For Overload Relays			Adjustable Relays (Note 4)	
				Furnas (Note 1)	Allen Bradley (Note 2)	G.E. (Note 3)	Set	Max.
1/2	0.37	200	00	K31	J16	L380A	3.2	3.4
		230	00	K28	J14	L343A	2.7	2.9
		380	00	K22	J9	L211A	1.7	1.8
		460	00	-	J8	L174A	1.4	1.5
		575	00	-	J6	-	1.2	1.3
3/4	0.55	200	00	K34	J19	L51CA	4.1	4.4
		230	00	K32	J17	L420A	3.5	3.8
		380	00	K27	J13	L282A	2.3	2.5
		460	00	K23	J10	L211A	1.8	1.9
		575	00	K21	J8	L193A	1.5	1.6
1	0.75	200	00	K37	J21	L618A	5.0	5.4
		230	00	K36	J19	L561A	4.4	4.7
		380	00	K28	J14	L310A	2.6	2.8
		460	00	K26	J12	L282A	2.2	2.4
		575	00	K23	J10	L211A	1.8	1.9
1 1/2	1.1	200	00	K42	J23	L750A	6.3	6.8
		230	00	K39	J21	L680A	5.5	5.9
		380	00	K32	J17	L420A	3.3	3.6
		460	00	K29	J15	L343A	2.8	3.0
		575	00	K26	J12	L282A	2.2	2.4
2	1.5	200	0	K50	J26	L111B	8.6	9.3
		230	0	K49	J25	L910A	7.5	8.1
		380	0	K36	J20	L561A	4.6	4.9
		460	00	K33	J18	L463A	3.8	4.1
		575	00	K29	J15	L380A	3.0	3.2
3	2.2	200	0	K55	J29	L147B	11.6	12.5
		230	0	K52	J28	L122B	10.1	10.9
		380	0	K41	J23	L750A	6.1	6.6
		460	0	K37	J21	L618A	5.1	5.5
		575	0	K34	J19	L510A	4.1	4.4
5	3.7	200	1	K62	J34	L241B	19.1	20.5
		230	1	K61	J33	L199B	16.6	17.8
		380	0	K52	J28	L122B	10.0	10.8
		460	0	K49	J26	L100B	8.3	8.9
		575	0	K42	J23	L825A	6.6	7.1
7 1/2	5.5	200	1	K68	J38	L332B	28.4	30.5
		230	1	K67	J37	L293B	24.6	26.4
		380	1	K58	J32	L181B	14.9	16.0
		460	1	K55	J30	L147B	12.3	13.2
		575	1	K52	J28	L122B	9.9	10.6
10	7.5	380	1	K63	J35	L265B	21.2	22.8
		460	1	K61	J33	L220B	17.5	18.8
		575	1	K57	J31	L181B	14.0	15.0



Application - Three Phase Motors

Table 25 60 Hz 6" Motors

HP	KW	Volts	NEMA Starter Size	Heaters For Overload Relays			Adjustable Relays (Note 4)	
				Furnas (Note 1)	Allen Bradley (Note 2)	G.E. (Note 3)	Set	Max.
5	3.7	200	1	K61	J33	L220B	17.6	19.1
		230	1	K60	J32	L199B	15.4	16.6
		380	0	K52	J27	L111B	9.4	10.1
		460	0	K49	J25	L910A	7.7	8.3
		575	0	K41	J23	L750A	6.1	6.6
7 1/2	5.5	200	1	K67	J38	L322B	26.3	28.3
		230	1	K64	J36	L293B	22.9	24.6
		380	1	K57	J31	L165B	13.9	14.9
		460	1	K54	J29	L147B	11.4	12.3
		575	1	K52	J27	L111B	9.1	9.8
10	7.5	200	2(1)	K72	J40	L426B	34.4	37.0
		230	2(1)	K70	J38	L390B	29.9	32.2
		380	1	K61	J34	L220B	18.1	19.5
		460	1	K58	J32	L181B	15.0	16.1
		575	1	K55	J30	L147B	12.0	12.9
15	11	200	3(1)	K76	J43	L650B	50.7	54.5
		230	2	K75	J42	L520B	44.1	47.4
		380	2(1)	K68	J37	L322B	26.7	28.7
		460	2(1)	K64	J35	L265B	22.0	23.7
		575	2(1)	K61	J33	L220B	17.7	19.0
20	15	200	3	K78	J45	L787B	64.8	69.7
		230	3(1)	K78	J44	L710B	56.4	60.6
		380	2	K72	J40	L426B	34.1	36.7
		460	2	K69	J38	L352B	28.2	30.3
		575	2	K64	J35	L393B	22.7	24.4
25	18.5	200	3	K86	J71	L107C	80.3	86.3
		230	3	K83	J46	L866B	69.8	75.0
		380	2	K74	J42	L520B	42.2	45.4
		460	2	K72	J40	L426B	34.9	37.5
		575	2	K69	J37	L352B	27.9	30.0
30	22	200	4(1)	K88	J72	L126C	96.7	104.0
		230	3	K87	J71	L107C	84.1	90.4
		380	3(1)	K76	J43	L650B	50.9	54.7
		460	3(1)	K74	J41	L520B	42.0	45.2
		575	3(1)	K72	J39	L390B	33.7	36.2
40	30	380	3	K83	J46	L866B	69.8	75.0
		460	3	K77	J44	L710B	57.7	62.0
		575	3	K74	J42	L593B	46.1	49.6
50	37	380	3	K87	J72	L107C	86.7	93.2
		460	3	K83	J46	L950C	71.6	77.0
		575	3	K77	J44	L710B	57.3	61.6
60	45	380	4(1)	K89	J73	L126C	102.5	110.2
		460	4(1)	K87	J71	L107C	84.6	91.0
		575	4(1)	K78	J45	L866B	67.7	72.8

Footnotes for Tables 24, 25, and 26

NOTE 1: Furnas intermediate sizes between NEMA starter sizes apply where (1) is shown in tables, size 1-3/4 replacing 2, 2-1/2 replacing 3, 3-1/2 replacing 4, and 4-1/2 replacing 5. Heaters were selected from Catalog 294, Table 332 and Table 632 (starter size 00, size B). Size 4 starters are heater type 4 (JG). Starters using these heater tables include classes 14, 17 and 18 (INNOVA), classes 36 and 37 (reduced voltage), and classes 87, 88 and 89 (pump and motor control centers). Overload relay adjustments should be set no higher than 100% unless necessary to stop nuisance tripping with measured amps in all lines below nameplate maximum. Heater selections for class 16 starters (Magnetic Definite Purpose) will be furnished upon request.

NOTE 2: Allen-Bradley heaters were selected from Catalog IC-110, Table 162 (through starter size 4), Table 547 (starter size 5), and Table 196 (starter size 6). Bulletin 505, 509, 520, 540 and 570 use these heater tables. Heater selections for bulletin 1232X and 1233X starters will be furnished upon request.

NOTE 3: General Electric heaters are type CR123 usable only on type CR124 overload relays and were selected from Catalog GEP-126OJ, page 184. Adjustment should be set no higher than 100%, unless necessary to stop nuisance tripping with measured amps in all lines below nameplate maximum.

NOTE 4: Adjustable overload relay amp settings apply to approved types listed. Relay adjustment should be set at the specified SET amps. Only if tripping occurs with amps in all lines measured to be within nameplate maximum amps should the setting be increased, not to exceed the MAX value shown.

NOTE 5: Heaters shown for ratings requiring NEMA size 5 or 6 starters are all used with current transformers per manufacturer standards. Adjustable relays may or may not use current transformers depending on design.



Application - Three Phase Motors

Recommended Adjustable Overload Relays

Advance Controls: MDR3 Overload

AEG Series: B17S, B27S, B27-2

ABB Type: RVH 40, RVH65, RVP160, T25DU, T25CT, TA25DU

AGUT: MT03, R1K1, R1L0, R1L3, TE set Class 5

Allen Bradley: Bulletin 193, SMP-Class 10 only

Automatic Switch Types: DQ, LR1-D, LR1-F, LR2-D13, -D23, -D33 only

Bharita C-H: MC 305 ANA 3

Clipsal: 6CTR, 6MTR

Cutler-Hammer: C316F, C316P, C316S, C310-set at 6 sec max

Fanal Types: K7 or K7D through K400

Franklin Electric: Subtrol-Plus

Fuji Types: TR-OQ, TR-OQH, TR-2NQ, TR-3NQ, TR-4NQ, TR-6NQ, RCa 3737-ICQ & ICQH

Furnas Types: US15 48AG & 48BG, ESP100-Class 10 only, 958L

General Electric: CR4G, CR7G, RT*1, RT*2, RTF3, RT*4, CR324X-Class 10 only

Kasuga: RU Set Operating Time Code = 10 & time setting 6 sec max

Klockner-Moeller Types: ZOO, Z1, Z4, PKZM1, PKZM3 & PKZ2

Lovato: RC9, RC22, RC80, RF9, RF25 & RF95

Matsushita: FKT-15N, 15GN, 15E, 15GE, FT-15N, FHT-15N

Mitsubishi: ET, TH-K12ABKP, TH-K20KF, TH-K20KP, TH-K20TAKF, TH-K60KF, TH-K60TAKF

Omron: K2CM Set Operating Timing Code = 10 & time setting 6 sec max, SE-KP24E time setting 6 sec max

Riken: PM1, PM3

Samwha: EOCSR Set for Class 5, EOCSR-ST, EOCSR-SE, EOCSR-AT time setting 6 sec max

Siemens Types: 3UA50, -52, -54, -55, -58, -59, -60, -61, -62, -66, -68, -70, 3VUI3, 3VE, 3UB (Class 5)

Sprecher and Schuh Types: CT, CT1, CTA 1, CT3K, CT3-12 thru CT3-42, KTA3, CEF1 & CET3 set at 6 sec max, CEP 7 Class 10, CT4, 6, & 7, CT3

Square D/Telemecanique: Class 9065 Types: TD, TE, TF, TG, TJ, TK, TR, TJE & TJF (Class 10) OR LR1-D, LR1-F, LR2-Class 10, Types 18A, 32A, SS- Class 10, SR-Class 10 and 63-A-LB Series. Integral 18,32,63, GV2-L, GV2-M, GV2-P, GV3-M (1.6-10 amp only)

Table 26 60 Hz 8" Motors

HP	KW	Volts	NEMA Starter Size	Heaters For Overload Relays			Adjustable Relays (Note 4)	
				Furnas (Note 1)	Allen Bradley (Note 2)	G.E. (Note 3)	Set	Max.
40	30	380	3	K78	J46	L866B	68	73
		460	3	K77	J43	L710B	56	60
		575	3	K73	J41	L520B	45	48
50	37	380	3	K86	J81	L107C	81	87
		460	3	K78	J46	L866B	68	73
		575	3	K77	J43	L710B	56	60
60	45	380	4(1)	K89	J72	L126C	101	108
		460	4(1)	K86	J70	L107C	83	89
		575	4(1)	K78	J44	L787B	64	69
75	55	380	4	K92	J75	L142C	121	130
		460	4(1)	K89	J72	L126C	100	107
		575	4(1)	K85	J70	L950C	79	85
100	75	380	5(1)	K28	J15	L100B	168	181
		460	4	K92	J76	L155C	134	144
		575	4	K90	J73	L142C	108	116
125	90	380	5	K32	J17	L135B	207	223
		460	5(1)	K29	J15	L111B	176	189
		575	5(1)	K26	J13	L825A	140	150
150	110	380	5	-	J19	L147B	248	267
		460	5(1)	K32	J17	L122B	206	221
		575	5(1)	K28	J14	L100B	165	177
175	130	380	6	K26	J11	-	270	290
		460	5	K33	J18	L147B	233	250
		575	5	K31	J16	L111B	186	200
200	150	380	6	K27	J12	-	316	340
		460	5	K33	J20	L165B	266	286
		575	5	K32	J17	L135B	213	229

Toshiba Type: 2E RC820, set at 8 seconds max.

WEG: RW2

Westinghouse Types: FT13, FT23, FT33, FT43, K7D, K27D, K67D, Advantage (Class 10), MOR, IQ500 (Class 5)

Westmaster: OLWROO and OLWTOO suffix D thru P

Other relay types from these and other manufacturers may or may not provide acceptable protection, and they should not be used without approval of Franklin Electric.

Some approved types may only be available for part of the listed motor ratings. When relays are used with current transformers, relay setting is the specified amps divided by the transformer ratio.



Application - Three Phase Motors

Subtrol-Plus

Subtrol-Plus is a Franklin Electric protection device for 6" and 8" motors that uses microprocessor technology to detect overload, underload, overheat, and rapid cycling. When one of these faults occurs, Subtrol-Plus shuts down the motor and visually displays the fault condition. Some additional features are automatic restart, field adjustable trip settings, and external alarm/back-up system connection.

Subtrol-Plus is supplied as an easy-to-install kit, which fits virtually any three-phase pump panel. Subtrol-Plus calibrates to a particular motor through the use of a rating insert.



Subtrol-Plus easy-to-install kit

Power Factor Correction

In some installations, power supply limitations make it necessary or desirable to increase the power factor of a submersible motor. The table lists the capacitive KVAR required to increase the power factor of large Franklin three phase submersible motors to the approximate values shown at maximum input loading.

Capacitors must be connected on the line side of the overload relay, or overload protection will be lost.

Table 27 KVAR Required 60 Hz

Motor		KVAR Required for P.F. of:		
HP	KW	0.90	0.95	1.00
5	3.7	1.2	2.1	4
7 1/2	5.5	1.7	3.1	6
10	7.5	1.5	3.3	7
15	11	2.2	4.7	10
20	15	1.7	5	12
25	18.5	2.1	6.2	15
30	22	2.5	7.4	18
40	30	4.5	11	24
50	37	7.1	15	32
60	45	8.4	18	38
75	55	6.3	18	43
100	75	11	27	60
125	90	17	36	77
150	110	20	42	90
175	130	9.6	36	93
200	150	16	46	110



Submersible Pump Installation Check List

1. Motor Inspection

- A. Verify that the model, HP or KW, voltage, phase and hertz on the motor nameplate match the installation requirements.
- B. Check that the motor lead assembly is not damaged.
- C. Measure insulation resistance using a 500 or 1000 volt DC megohmmeter from each lead wire to the motor frame. Resistance should be at least 20 megohms with out drop cable.
- D. Keep a record of motor model number, HP or KW, voltage, and serial number (S/N). (S/N is stamped in shell above the nameplate. A typical example, S/N 98A18 01-0123)

2. Pump Inspection

- A. Check that the pump rating matches the motor.
- B. Check for pump damage and verify that the pump shaft turns freely.

3. Pump/Motor Assembly

- A. If not yet assembled, check that pump and motor mounting faces are free from dirt, debris and uneven paint thickness.
- B. Pumps and motors over 5HP should be assembled in the vertical position to prevent stress on pump brackets and shafts. Assemble the pump and motor together so their mounting faces are in contact and then tighten assembly bolts or nuts evenly to manufacturer specifications.
- C. If accessible, check that the pump shaft turns freely.
- D. Assemble the pump lead guard over the motor leads. Do not cut or pinch lead wires during assembly or installation.

4. Power Supply and Controls

- A. Verify that the power supply voltage, hertz, and KVA capacity match motor requirements.
- B. Verify control box HP and voltage matches motor (3-wire only).
- C. Check that the electrical installation and controls meet all safety regulations and match the motor requirements, including fuse or circuit breaker size and motor overload protection. Connect all metal plumbing and electrical enclosures to the power supply ground to prevent shock hazard. Comply with national and local codes.

5. Lightning and Surge Protection

- A. Use properly rated surge (lightning) arrestors on all submersible pump installations. Motors 5HP and smaller, which are marked "Equipped with Lightning Arrestors", contain internal arrestors.
- B. Ground all above ground arrestors with copper wire directly to the motor frame, or to metal drop pipe or casing which reaches below the well pumping level. Connecting to a ground rod does not provide good surge protection.

6. Electrical Drop Cable

- A. Use submersible cable sized in accordance with local regulations and the cable charts, see Pages 11 and 15-20. Ground motor per national and local codes.
- B. Include a ground wire to the motor and surge protection, connected to the power supply ground if required by codes. Always ground any pump operated outside a drilled well.

7. Motor Cooling

- A. Ensure at all times the installation provides adequate motor cooling; see Page 6 for details.

8. Pump/Motor Installation

- A. Splice motor leads to supply cable using electrical grade solder or compression connectors, and carefully insulate each splice with watertight tape or adhesive-lined shrink tubing, as shown in motor or pump installation data.
- B. Support the cable to the delivery pipe every 10 feet (3 meters) with straps or tape strong enough to prevent sagging. Use padding between cable and any metal straps.
- C. A check valve in the delivery pipe is recommended. More than one check valve may be required, depending on valve rating and pump setting; see Page 5 for details.
- D. Assemble all pipe joints as tightly as practical, to prevent unscrewing from motor torque. Torque should be at least 10 pound feet per HP (2 meter-KG per KW).
- E. Set the pump far enough below the lowest pumping level to assure the pump inlet will always have at least the Net Positive Suction Head (NPSH) specified by the pump manufacturer. Pump should be at least 10 feet (3 meters) from the bottom of the well to allow for sediment build up.
- F. Check insulation resistance as pump/motor assembly is lowered into the well. Resistance may drop gradually as more cable enters the water, but any sudden drop indicates possible cable, splice or motor lead damage; see Page 39.



Submersible Pump Installation Check List

9. After Installation

- A. Check all electrical and water line connections and parts before starting the pump.
- B. Start the pump and check motor amps and pump delivery. If normal, continue to run the pump until delivery is clear. If three phase pump delivery is low, it may be running backward. Rotation may reversed (with power off) by interchanging any two motor lead connections to the power supply.
- C. Check three phase motors for current balance within 5% of average, using motor manufacturer instructions. Imbalance over 5% will cause higher motor temperatures and may cause overload trip, vibration, and reduced life.
- D. Verify that starting, running and stopping cause no significant vibration or hydraulic shocks.
- E. After at least 15 minutes running time, verify that pump output, electrical input, pumping level, and other characteristics are stable and as specified.

Date _____ Filled In By _____

Notes _____



Submersible Motor Installation Record

RMA No. _____

INSTALLER'S NAME _____ OWNER'S NAME _____

ADDRESS _____ ADDRESS _____

CITY _____ STATE _____ ZIP _____ CITY _____ STATE _____ ZIP _____

PHONE (____) _____ FAX (____) _____ PHONE (____) _____ FAX (____) _____

CONTACT NAME _____ CONTACT NAME _____

WELL NAME/ID _____ DATE INSTALLED _____ DATE FAILED _____

WATER TEMPERATURE _____ °F or _____ °C

MOTOR:

Motor No. _____ Date Code _____ HP _____ Voltage _____ Phase _____

PUMP:

Manufacturer _____ Model No. _____ Curve No. _____ Rating: _____ GPM@ _____ ft. TDH

NPSH Required _____ ft. NPSH Available _____ ft. Actual Pump Delivery _____ GPM@ _____ PSI

Operating Cycle _____ ON (Min./Hr.) _____ OFF (Min./Hr.) (Circle Min. or Hr. as appropriate)

YOUR NAME _____ DATE ____/____/____

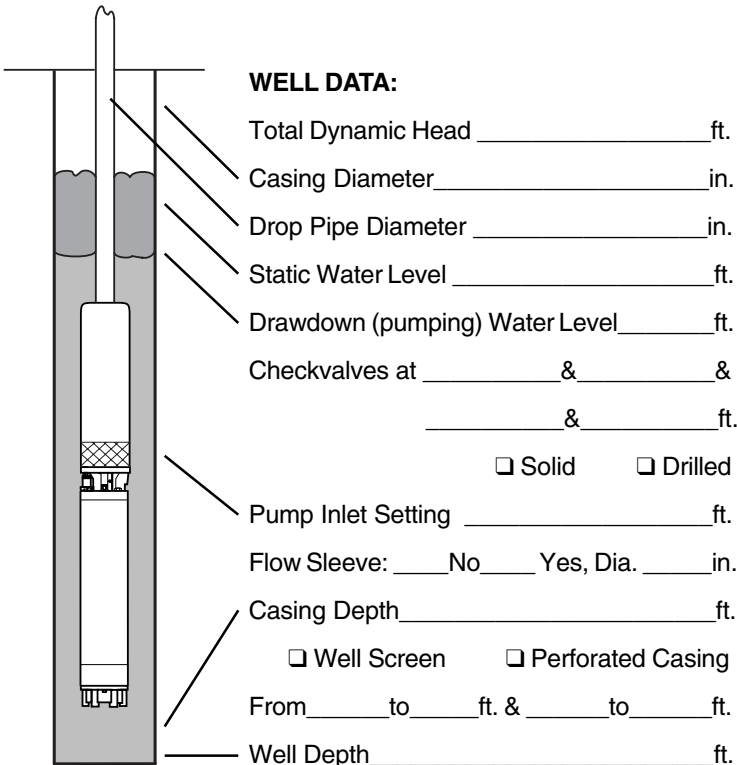

TOP PLUMBING:
Please sketch the plumbing after the well head (check valves, throttling valves, pressure tank, etc.) and indicate the setting of each device.



Submersible Motor Installation Record

POWER SUPPLY:

Cable: Service Entrance to Control _____ ft. _____ AWG/MCM Copper Aluminum
 Jacketed Individual Conductors

Cable: Control to Motor _____ ft. _____ AWG/MCM Copper Aluminum
 Jacketed Individual Conductors

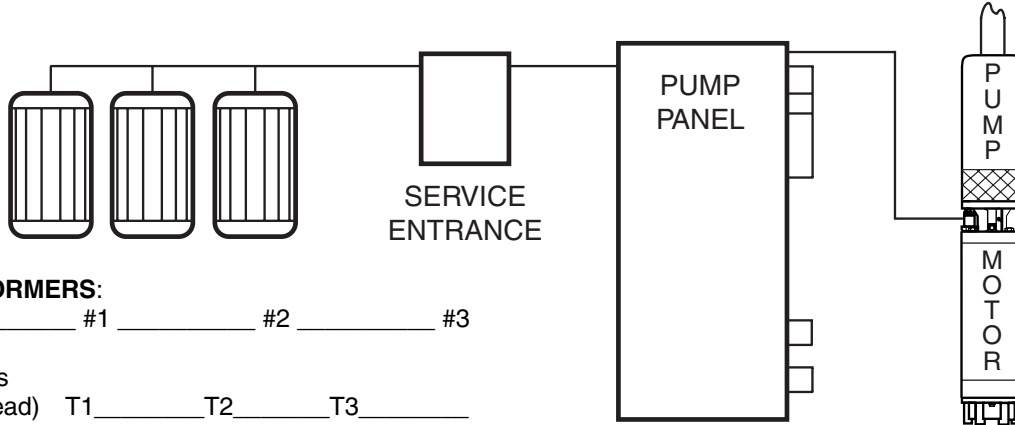

TRANSFORMERS:

KVA _____ #1 _____ #2 _____ #3

Initial Megs (motor & lead) T1 _____ T2 _____ T3 _____

Final Megs (motor, lead & cable) T1 _____ T2 _____ T3 _____

INCOMING VOLTAGE:

No Load L1-L2 _____ L2-L3 _____ L1-L3 _____
Full Load L1-L2 _____ L2-L3 _____ L1-L3 _____

RUNNING AMPS:

HOOKUP 1:
Full Load L1 _____ L2 _____ L3 _____
%Unbalance _____

HOOKUP 2:
Full Load L1 _____ L2 _____ L3 _____
%Unbalance _____

HOOKUP 3:
Full Load L1 _____ L2 _____ L3 _____
%Unbalance _____

Ground Wire Size _____ AWG/MCM
DC Ground Current _____ mA
Motor Surge Protection Yes No

VARIABLE FREQUENCY DRIVES:

Manufacturer _____ Model _____ Output Frequency: _____ Hz Min _____ Hz Max
Cooling Flow at Min. Freq. _____ Cooling Flow at Max. Freq. _____
Approved Overload: Built-in _____ External Model: (per above) Cables: (per above) Set Amps _____
Start Time _____ sec. Stop Mode Coast _____ sec. Ramp _____ sec.
 Output filter _____ Reactor _____ % Make _____ Model _____ None

MAXIMUM LOAD AMPS:

Drive Meter Input Amps Line 1 _____ Line 2 _____ Line 3 _____
Drive Meter Output Amps Line 1 _____ Line 2 _____ Line 3 _____
Test Ammeter Output Amps Line 1 _____ Line 2 _____ Line 3 _____
Test Ammeter Make _____ Model _____

CONTROL PANEL:

Panel Manufacturer _____
Short Circuit Device Circuit Breaker Rating _____ Setting _____
 Fuses Rating _____ Type _____
 Standard Delay

Starter Manufacturer _____
Starter Size _____
Type of Starter Full Voltage Autotransformer
 Other: _____ Full Voltage in _____ sec.

Heater Manufacturer _____
Number _____ Adjustable Set at _____ amps.
Subtrol-Plus No Yes Registration No. _____
If yes, Overload Set? No Yes Set at _____ amps.
Underload Set? No Yes Set at _____ amps.

Controls are Grounded to:
 Well Head Motor Rod Power Supply



Submersible Motor Booster Installation Record

Submersible Motor Booster Installation Record

Date ____ / ____ / ____ Filled In By _____ RMA No. _____

Installation

Owner/User _____ Telephone (____) _____

Address _____ City _____ State _____ Zip _____

Installation Site, If Different _____

Contact _____ Telephone (____) _____

System Application _____

System Manufactured By _____ Model _____ Serial No. _____

System Supplied By _____ City _____ State _____ Zip _____

Motor

Model No. _____ Serial No. _____ Date Code _____

Horsepower _____ Voltage _____ Single Phase Three Phase Diameter _____ In.

Slinger Removed? Yes No Check Valve Plug Removed? Yes No

Pump

Manufacturer _____ Model _____ Serial No. _____

Stages _____ Diameter _____ Flow Rate Of _____ GPM At _____ TDH

Booster Case Internal Diameter _____ Construction _____

Controls and Protective Devices

Subtrol? Yes No If Yes, Warranty Registration No. _____

If Yes, Overload Set? Yes No _____ Set At _____

Underload Sets? Yes No _____ Set At _____

Reduced Voltage Starter? Yes No If Yes, Type _____

Mfr. _____ Setting _____ %Full Voltage In _____ Seconds

Pump Panel? Yes No If Yes, Mfr. _____ Size _____

Magnetic Starter/Contactor Mfr. _____ Model _____ Size _____

Heaters Mfr. _____ No. _____ If Adjustable Set At _____

Fuses Mfr. _____ Size _____ Type _____

Lightning/Surge Arrestor Mfr. _____ Model _____

Controls Are Grounded to _____ with No. _____ Wire

Inlet Pressure Control Yes No If Yes, Mfr. _____ Model _____ Setting _____ PSI

Inlet Flow Control Yes No If Yes, Mfr. _____ Model _____ Setting _____ GPM

Outlet Pressure Control Yes No If Yes, Mfr. _____ Model _____ Setting _____ PSI

Outlet Flow Control Yes No If Yes, Mfr. _____ Model _____ Setting _____ GPM

Water Temperature Control Yes No If Yes, Mfr. _____ Model _____

Set At _____ °F Or _____ °C Located _____



Submersible Motor Booster Installation Record

Insulation Check

Initial Megs: Motor & Lead Only Black _____ Yellow _____ Red _____
 Installed Megs: Motor, Lead, & Cable Black _____ Yellow _____ Red _____

Voltage To Motor

Non-Operating: B-Y _____ Y-R _____ R-B _____
 At Rated Flow of _____ GPMB-Y _____ Y-R _____ R-B _____
 At Open Flow _____ GPM B-Y _____ Y-R _____ R-B _____

Amps To Motor

At Rated Flow of _____ GPM Black _____ Yellow _____ Red _____
 At Open Flow _____ GPM Black _____ Yellow _____ Red _____
 At Shut Off* Black _____ Yellow _____ Red _____

*Do **NOT** run at Shut Off more than two (2) minutes.

Inlet Pressure _____ PSI Outlet Pressure _____ PSI Water Temperature _____ °F or _____ °C

Warranty on three phase motors is void unless Subtrol or proper quick trip ambient compensated protection is used on all three (3) motor lines.

If you have any questions or problems, call the Franklin Electric Toll-Free Hot Line: 1-800-348-2420

Comments: _____

Please sketch the system



Application - Three Phase Motors

Three Phase Starter Diagrams

Three phase combination magnetic starters have two distinct circuits: a power circuit and a control circuit.

The power circuit consists of a circuit breaker or fused line switch, contacts, and overload heaters connecting incoming power lines L1, L2, L3 and the three phase motor.

The control circuit consists of the magnetic coil, overload

contacts and a control device such as a pressure switch. When the control device contacts are closed, current flows through the magnetic contactor coil, the contacts close, and power is applied to the motor. Hands-Off-Auto switches, start timers, level controls and other control devices may also be in series in the control circuit.

Line Voltage Control

This is the most common type of control encountered. Since the coil is connected directly across the power lines, L1 and L2, the coil must match the line voltage.

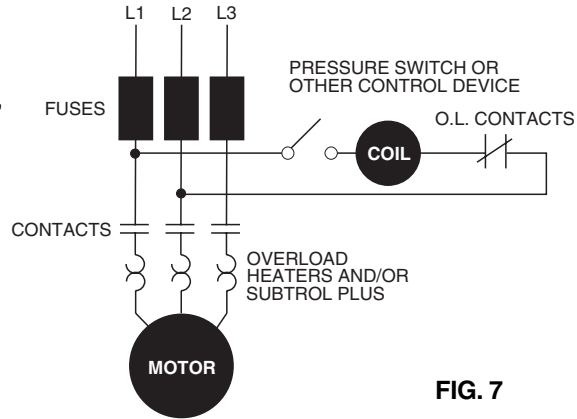

FIG. 7

Low Voltage Transformer Control

This control is used when it is desirable to operate push buttons or other control devices at some voltage lower than the motor voltage. The transformer primary must match the line voltage and the coil voltage must match the secondary voltage of the transformer.

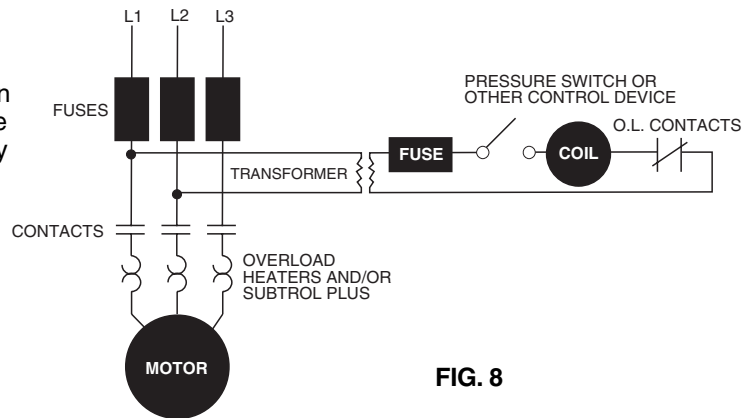

FIG. 8

External Voltage Controls

Control of a power circuit by a lower circuit voltage can also be obtained by connecting to a separate control voltage source. The coil rating must match the control voltage source, such as 115 or 24 volts.

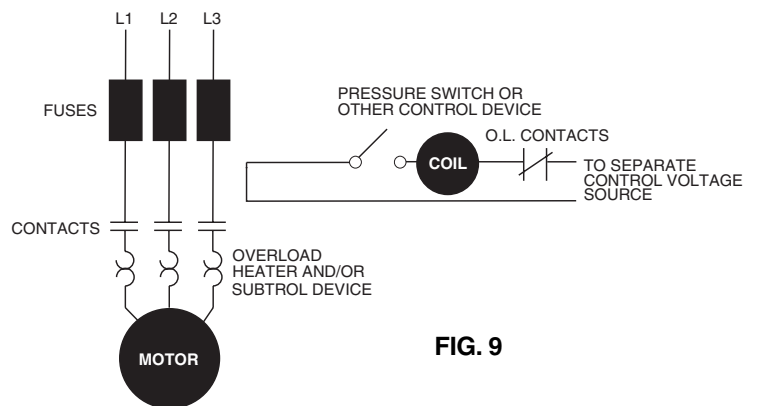

FIG. 9



Application - Three Phase Motors

Three Phase Power Unbalance

A full three phase supply is recommended for all three phase motors, consisting of three individual transformers or one three phase transformer. So-called "open" delta or wye connections using only two transformers can be used, but are more likely to cause problems, such as poor

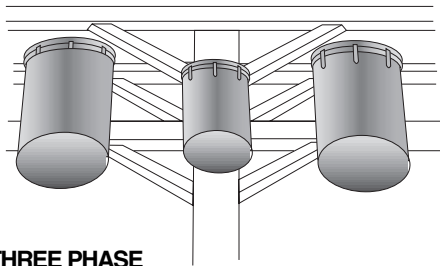

FIG. 10 FULL THREE PHASE

performance, overload tripping or early motor failure due to current unbalance.

Transformer rating should be no smaller than listed in Table 4 for supply power to the motor alone.

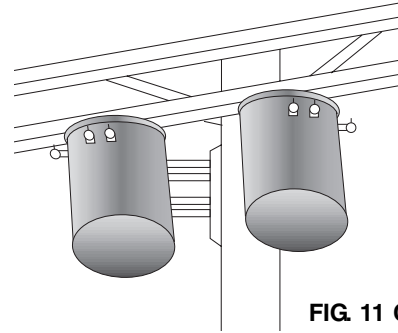

FIG. 11 OPEN DELTA

Checking And Correcting Rotation And Current Unbalance

- Established correct motor rotation by running in both directions. Change rotation by exchanging any two of the three motor leads. The rotation that gives the most water flow is always the correct rotation.
- After correct rotation has been established, check the current in each of the three motor leads and calculate the current unbalance as explained in 3 below.

If the current unbalance is 2% or less, leave the leads as connected.

If the current unbalance is more than 2%, current readings should be checked on each leg using each of three possible hook-ups. Roll the motor leads across the starter in the same direction to prevent motor reversal.

- To calculate percent of current unbalance:
 - Add the three line amps values together.
 - Divide the sum by three, yielding average current.
 - Pick the amp value which is furthest from the average current (either high or low).
 - Determine the difference between this amp value (furthest from average) and the average.
 - Divide the difference by the average. Multiply the result by 100 to determine percent of unbalance.
- Current unbalance should not exceed 5% at service factor load or 10% at rated input load. If the unbalance cannot be corrected by rolling leads, the source of the unbalance must be located and corrected. If, on the three possible hookups, the leg farthest from the average stays on the same power lead, most of the unbalance is coming from the power source. However, if the reading farthest from average moves with the same motor lead, the primary source of unbalance is on the "motor side" of the starter. In this instance, consider a damaged cable, leaking splice, poor connection, or faulty motor winding.

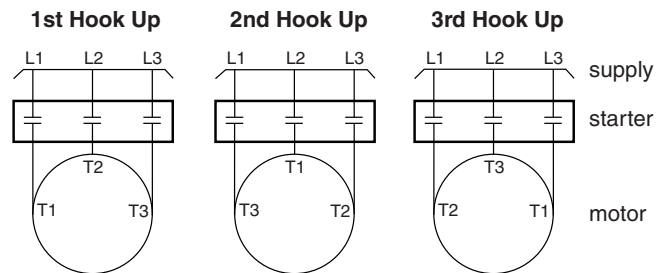

EXAMPLE:

T1 = 50 amps	T3 = 51 amps	T2 = 50 amps
T2 = 49 amps	T1 = 46 amps	T3 = 48 amps
+ T3 = 51 amps	+ T2 = 53 amps	+ T1 = 52 amps
Total = 150 amps	Total = 150 amps	Total = 150 amps
$\frac{150}{3} = 50$ amps	$\frac{150}{3} = 50$ amps	$\frac{150}{3} = 50$ amps
50 - 49 = 1 amp	50 - 46 = 4 amps	50 - 48 = 2 amps
$\frac{1}{50} = .02$ or 2%	$\frac{4}{50} = .08$ or 8%	$\frac{2}{50} = .04$ or 4%

Phase designation of leads for CCW rotation viewing shaft end.

To reverse rotation, interchange any two leads.

Phase 1 or "A"- Black, T1, or U1

Phase 2 or "B"- Yellow, T2, or V1

Phase 3 or "C"- Red, T3, or W1

NOTICE: Phase 1, 2 and 3 may not be L1, L2 and L3.



Application - Three Phase Motors

Three Phase Motor Lead Identification

90° Lead Spacing

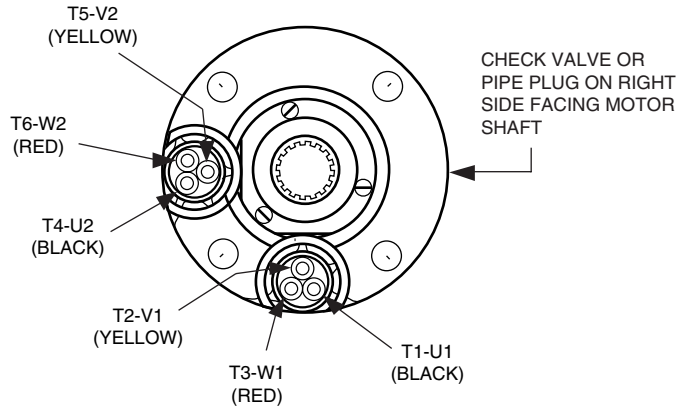

LEADS LOCATED HERE ONLY FOR 3 LEAD (DOL) MOTORS

Line Connections — Six Lead Motors

Connections for across-the-line starting, running, and any reduced voltage starting except WYE-DELTA type starters.

WYE-DELTA starters connect the motor as shown below during starting, then change to the running connection shown at the left.

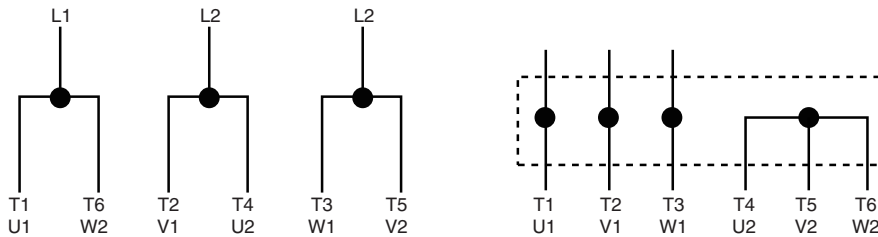

Each motor lead is numbered with two markers, one near each end. To reverse rotation. Interchange any two line connections.

Phase Converters

There are a number of different types of phase converters available. Each generates three phase power from a single phase power line.

In all phase converters, the voltage balance is critical to current balance. Although some phase converters may be well balanced at one point on the system-operating curve, submersible pumping systems often operate at differing points on the curve as water levels and operating pressures fluctuate. Other converters may be well balanced at varying loads, but their output may vary widely with fluctuations in the input voltage.

The following guidelines have been established for submersible installations to be warrantable when used with a phase converter.

1. Limit pump loading to rated horsepower. Do not load into

motor service factor.

2. Maintain at least 3 ft/sec. flow past the motor. Use a flow sleeve when necessary.
3. Use time delay fuses or circuit breakers in pump panel. Standard fuses or circuit breakers do not provide secondary motor protection.
4. Subtrol-Plus may be used with electro mechanical type phase converters, however special connections are required. Consult Subtrol-Plus Manual for connections of receiver and lighting arrestor.
5. Subtrol-Plus will not work with electronic solid state phase converters.
6. Current unbalance must not exceed 10%.



Application - Three Phase Motors

Reduced Voltage Starters

All Franklin three phase submersible motors are suitable for full voltage starting. Under this condition the motor speed goes from zero to full speed within a half second or less. The load current goes from zero to locked rotor amps, about 5 to 7 times running amps, and drops to running amps at full speed. This may dim lights, cause momentary voltage dips to other electrical equipment, and shock load power distribution transformers.

Power companies may require reduced voltage starters to limit this voltage dip if started "directly on line". There are also times when it may be desirable to reduce motor starting torque. This lessens the stress on shafts, couplings, and castings, as well as the supporting discharge piping. A "strong" voltage supply and a small cable voltage drop produces higher starting torque. Reduced voltage starters are used to reduce starting current or torque, and slow the immediate acceleration of the water on start up to control upthrust and water hammer.

With maximum recommended cable length, there is a 5% voltage drop in the cable, and there will be about 20% reduced starting current and about 36% reduction in starting torque compared to having rated voltage at the motor. This may be enough reduction in starting current so that reduced voltage starters may not be required.

Standard three phase motors have three line leads so only resistance, autotransformer, or solid state reduced voltage starters may be used. The autotransformer type is preferred over resistance and solid state types because it draws lower line current for the same starting torque.

Wye-Delta starters are used with six lead Wye-Delta motors. All Franklin 6" and 8" three phase motors are available in six lead Wye-Delta construction. Consult the factory for details and availability. Part winding starters are not usable with Franklin Electric submersible motors.

When reduced voltage starters are used, it is recommended that the motor be supplied with at least 55% of rated voltage to ensure adequate starting torque.

Most autotransformers starters have 65% and 85% taps. Setting the taps on these starters depends on the percentage of the maximum allowable cable length used in the system. If the cable length is less than 50% of the maximum allowable, either the 65% or the 80% taps may be used. When the cable length is more than 50% of allowable, the 80% tap should be used.

Solid state reduced voltage starters may be used with submersibles, but are not usable with Subtrol-Plus.

Both electromechanical and solid state starters have adjustable time delays for starting. Typically they are preset at 30 seconds. They must be set so the motor is at full voltage within TWO TO THREE SECONDS MAXIMUM to prevent overload trip and unnecessary heating.

Open transition starters, which momentarily interrupt power during the starting cycle, are not recommended. Only closed transition starters, which have no interruption of power during the start cycle, should be used.

Inline Booster Pump Systems

Franklin submersible motors are acceptable for booster pump (canned) applications providing the following conditions are taken into consideration in the system design.

1. **Horizontal Operation:** Horizontal operation is acceptable as long as the pump transmits thrust to the motor and the entire assembly is supported sufficiently to prevent binding stresses.
2. **Motor Support:** The motor support assembly must not restrict the flow of cooling water around the full diameter of the motor. The motor supports must be on the motor endbell castings, and not on the motor shell.
3. **Motor Alterations:** On 6" and 8" motors, the sand slinger should be removed. The pipe plug covering the check valve should be removed from Ni-resist and 316 SS motors.
4. **Controls:** Franklin Subtrol-Plus is strongly recommended for all large submersibles. If Subtrol-Plus is not employed, properly sized ambient compensated quick-trip overloads must be utilized. In addition, a surge arrestor should be installed on all systems and properly grounded.
5. **Wiring:** Franklin's lead assemblies are sized for submerged operation and may not be adequate for use in open air. Any wiring not submerged must comply with Franklin's cable charts.
6. **Water Temperature:** The temperature of the water should be monitored at the inlet to each booster. When temperatures exceed 86°F (30°C), motor derating is required.
7. **Inlet Pressure:** The inlet pressure on each booster should be monitored and not be allowed below the pump's specified Net Positive Suction Head Requirements (NPSHR). If NPSHR is unknown, at least 20 PSI should be maintained at all times. **At no time should the pressure surrounding the motor be less than one atmosphere.**
8. **Discharge Flow:** The flow rate for each pump should not be allowed to drop below the minimum required maintaining cooling flow velocities. Pressure relieving valves should be employed to prevent running the pump at shut-off.
9. **Discharge Pressure:** The discharge pressure should be great enough to prevent upthrust.
10. **Can Flooding:** An air bleeder valve must be employed on the booster can so that flooding may be accomplished prior to booster start-up. Once flooding is complete, the booster should be started



Application - Three Phase Motors

Inline Booster Pump Systems (continued)

as quickly as possible to minimize the chance of upthrust. Water should never be forced through the booster can (more than momentarily) without the pump running as failure due to upthrust may occur.

IMPORTANT NOTES:

1. **High Pressure Tests:** Motors intended for booster applications where the pressure exceeds 500 PSI must be special ordered from the factory.
2. **Starting:** Reduced voltage starting may be employed. This will reduce upthrust on start, starting current, and mechanical stresses created by the motor's high starting torque. Reduced voltage starters, if used should accelerate the motor to full speed within two seconds. Note: Solid state reduced voltage starters are not compatible with Subtrol-Plus.

Variable Speed Submersible Pump Operation, Inverter Drives

Franklin three phase submersible motors are operable from variable frequency inverter drives when applied within guidelines shown below. These guidelines are based on present Franklin information for inverter drives, lab tests and actual installations, and must be followed for warranty to apply to inverter drive installations. Franklin two-wire and three-wire single phase submersible motors are not recommended for variable speed operation.

Warning: There is a potential shock hazard from contact with insulated cables from a PWM drive to the motor. This hazard is due to high frequency voltage content of a PWM drive output.

Load Capability: Pump load should not exceed motor nameplate service factor amps at rated voltage and frequency.

Volts/Hz: Use motor nameplate volts and frequency for the drive base settings. Many drives have means to increase efficiency at reduced pump speeds by lowering motor voltage. This is the preferred operating mode.

Motor Current Limits: Load no higher than motor nameplate service factor amps. For 50 Hz ratings, nameplate maximum amps are rated amps. See Overload Protection below.

Carrier Frequency: Applicable to PWM drives only. These drives often allow selection of the carrier frequency. Use a low carrier frequency.

Voltage Rise-time or dV/dt : Limit the voltage peak at the motor to 1000V and the rise time to no more than 2 μ sec. See filters and reactors.

Motor Overload: Follow the Franklin guidelines listed in the Application Installation Maintenance (AIM) Manual.

Protection: Drives with built-in motor protection will meet Franklin's quick-trip overload requirements. The ultimate trip (not the setting) must not exceed 115% of nameplate maximum amps in any line.

Subtrol-Plus: Franklin's Subtrol-Plus protection systems ARE NOT USABLE on VFD installations.

Frequency Range: Continuous between 30 and 60 Hz. Consult factory for operations above 60 Hz.

Start and Stop: One second maximum ramp-up and ramp-down times between stopped and 30 Hz. Stopping by coast-down is preferable.

Successive Starts: Allow 60 seconds before restarting.

Filters or Reactors: Required if (1) Voltage is 380 or greater and (2) Drive uses IGBT or BJT switches (rise-times < 2 msec) and (3) Cable from drive to motor is more than 50 ft. A low-pass filter is preferable. Filters or reactors should be selected in conjunction with the drive manufacturer and must be specifically designed for VFD operation.

Cable Lengths : Per Franklin's cable tables.

Motor Cooling Flow: The flow rate past the motor at rated nameplate motor frequency (Hz) must meet Franklin's minimum flow requirements. 4" .25 ft./sec. and 6" and 8" .5 ft./sec.



Installation - All Motors

4" Super Stainless — Dimensions

(Standard Water Well)

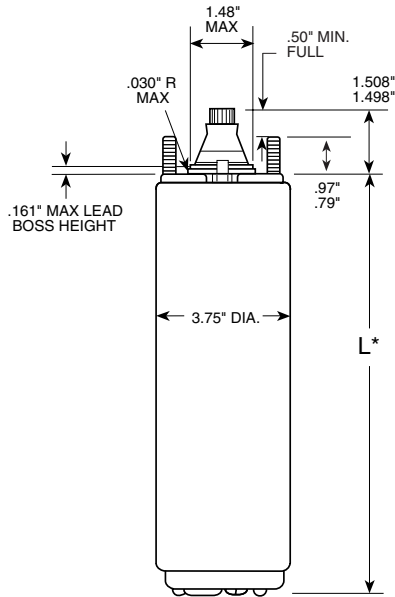

4" High Thrust — Dimensions

(Standard Water Well)

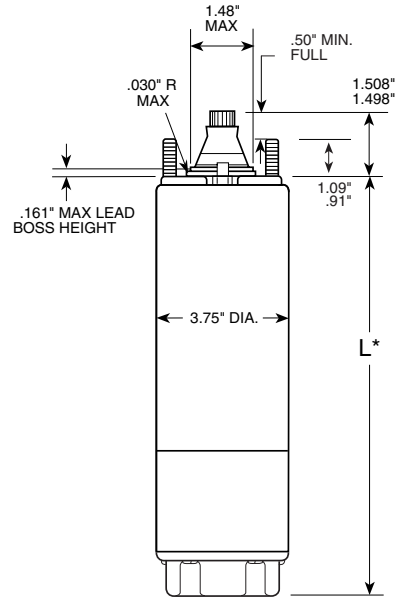

6" — Dimensions

(Standard Water Well)

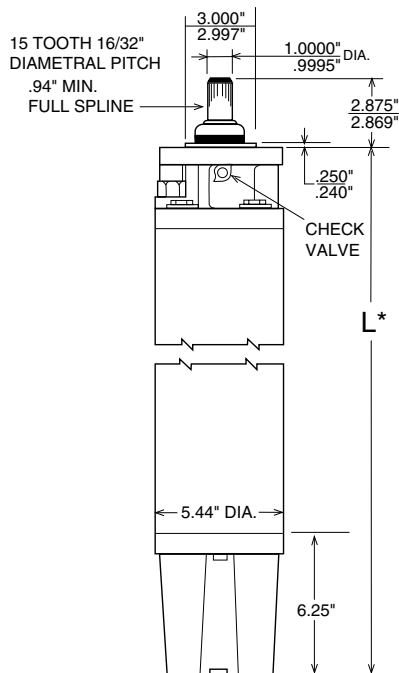

8" — Dimensions

(Standard Water Well)

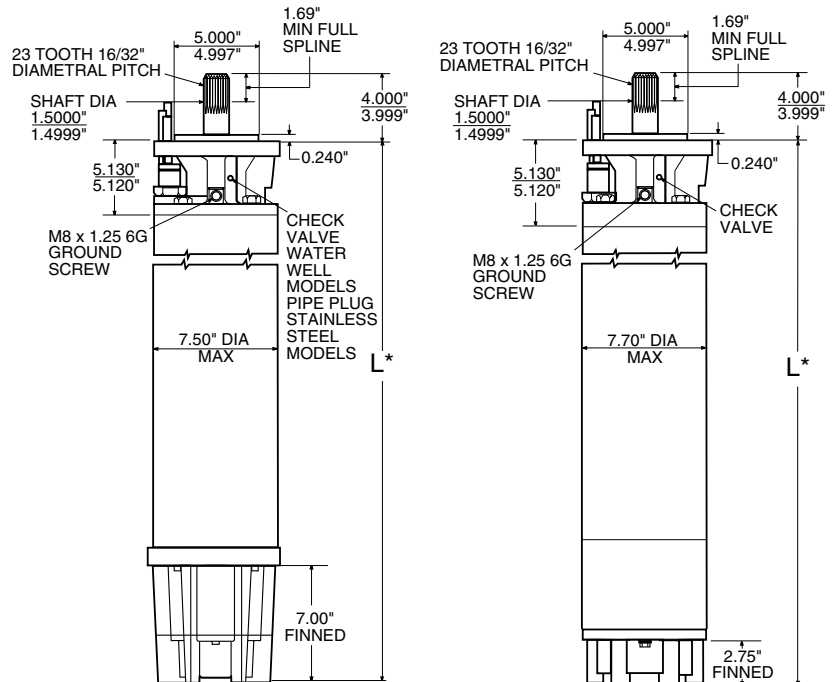

40 to 100 HP

125 to 200 HP

* Motor lengths and shipping weights are available on Franklin Electric's web page (www.franklin-electric.com) or by calling Franklin's submersible hotline (800-348-2420).



Installation - All Motors

Tightening Motor Lead Connector Jam Nut

4" Motors - 15 to 20 ft-lb. (20 to 27 N-m)
 6" Motors - 50 to 60 ft-lb. (68 to 81 N-m)
 8" Motors with: 1-3/16" to 1-5/8" Jam Nut - 50 to 60 ft-lb. (68 to 81 N-m)
 8" Motors with 4 Screw Clamp Plate: Apply increasing torque to the screws equally in a criss-cross pattern until 80 to 90 in-lb. (9.0 to 10.2 N-m) is reached.

A motor lead assembly should not be reused. A new lead assembly should be used whenever one is removed from the motor, because rubber set and possible damage from removal may prevent proper resealing of the old lead.

All motors returned for warranty consideration must have the lead returned with the motor.

Pump to Motor Coupling

Assemble coupling with non-toxic FDA approved waterproof grease such as Mobile FM102, Texaco CYGNUS2661, or approved equivalent. This prevents abrasives from entering the spline area and prolongs spline life.

Shaft Height and Free End Play

Table 34

Motor	Normal Shaft Height		Dimension Shaft Height		Free End Play	
					Min.	Max.
4"	1 1/2"	38.1 mm	1.508"	38.30	.010"	.045"
			1.498"	38.05 mm	.25 mm	1.14 mm
6"	2 7/8"	73.0 mm	2.875"	73.02	.030"	.050"
			2.869"	72.88 mm	.75 mm	1.25 mm
8" Type 1	4"	101.5 mm	4.000"	101.60	.008"	.020"
			3.990"	101.35 mm	.20 mm	.50 mm
8" Type 2	4"	101.5 mm	4.000"	101.60	.035"	.060"
			3.990"	101.35 mm	.89 mm	1.52 mm
8" Type 2.1	4"	101.5 mm	4.000"	101.60	.030"	.080"
			3.990"	101.35 mm	.75 mm	2.03 mm

If the height, measured from the pump-mounting surface of the motor, is low and/or end play exceeds the limit, the motor thrust bearing is possibly damaged, and should be replaced.

Submersible Leads and Cables

A common question is why motor leads are smaller than specified in Franklin's cable charts.

The leads are considered a part of the motor and actually are a connection between the large supply wire and the motor winding. The motor leads are short and there is virtually no voltage drop across the lead.

In addition, the lead assemblies **operate under water**, while at least part of the supply cable must **operate in air**. Lead assemblies running under water operate cooler.

CAUTION: Lead assemblies on submersible motors are suitable only for use in water and may overheat and cause failure if operated in air.



Installation - All Motors

Splicing Submersible Cables

When the drop cable must be spliced or connected to the motor leads, it is necessary that the splice be watertight. This splice can be made with commercially available potting, heat shrink splicing kits, or by careful tape splicing.

Tape splicing should use the following procedure.

- A) Strip individual conductor of insulation only as far as necessary to provide room for a stake type connector. Tubular connectors of the staked type are preferred. If connector outside diameter (OD) is not as large as cable insulation, build up this area with rubber electrical tape.
- B) Tape individual joints with rubber electrical tape, using two layers, with the first layer extending two inches

beyond each end of the conductor insulation end, and the second layer extending two inches beyond the ends of the first layer. Wrap tightly, eliminating air spaces as much as possible.

- C) Tape over the rubber electrical tape with #33 Scotch electrical tape, (3M) or equivalent, using two layers as in step "B" and making each layer overlap the end of the preceding layer by at least two inches.

In the case of a cable with three conductors encased in a single outer sheath, tape individual conductors as described, staggering joints.

Total thickness of tape should be no less than the thickness of the conductor insulation.

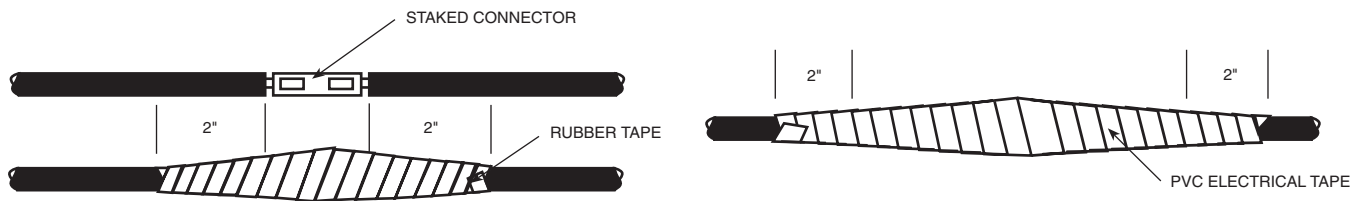

FIG. 12



Maintenance - All Motors

System Trouble Shooting

Motor Does Not Start

Possible Cause	Checking Procedures	Corrective Action
A. No power or incorrect voltage.	Check voltage at line terminals. The voltage must be $\pm 10\%$ of rated voltage.	Contact power company if voltage is incorrect.
B. Fuses blown or circuit breakers tripped.	Check fuses for recommended size and check for loose, dirty or corroded connections in fuse receptacle. Check for tripped circuit breakers.	Replace with proper fuse or reset circuit breakers.
C. Defective pressure switch.	Check voltage at contact points. Improper contact of switch points can cause voltage less than line voltage.	Replace pressure switch or clean points.
D. Control box malfunction.	For detailed procedure, see pages 40-41.	Repair or replace.
E. Defective wiring	Check for loose or corroded connections or defective wiring.	Correct faulty wiring or connections.
F. Bound pump.	Check for misalignment between pump and motor or a sand bound pump. Amp readings will be 3 to 6 times higher than normal until the overload trips.	Pull pump and correct problem. Run new installation until the water clears.
G. Defective cable or motor.	For detailed procedure, see pages 38-40.	Repair or replace.

Motor Starts Too Often

A. Pressure switch.	Check setting on pressure switch and examine for defects.	Reset limit or replace switch.
B. Check valve - stuck open.	Damaged or defective check valve will not hold pressure.	Replace if defective.
C. Waterlogged tank.	Check air charge.	Repair or replace.
D. Leak in system.	Check system for leaks.	Replace damaged pipes or repair leaks.



Maintenance - All Motors

System Trouble Shooting

Motor Runs Continuously

Possible Cause	Checking Procedures	Corrective Action
A. Pressure switch.	Check switch for welded contacts. Check switch adjustments.	Clean contacts, replace switch, or adjust setting.
B. Low water level in well.	Pump may exceed well capacity. Shut off pump, wait for well to recover. Check static and drawdown level from well head.	Throttle pump output or reset pump to lower level. Do not lower if sand may clog pump.
C. Leak in system.	Check system for leaks.	Replace damaged pipes or repair leaks.
D. Worn pump.	Symptoms of worn pump are similar to those of drop pipe leak or low water level in well. Reduce pressure switch setting, if pump shuts off worn parts may be the fault.	Pull pump and replace worn parts.
E. Loose coupling or broken motor shaft.	Check for loose coupling or damaged shaft.	Replace worn or damaged parts.
F. Pump screen blocked.	Check for clogged intake screen.	Clean screen and reset pump depth.
G. Check valve stuck closed.	Check operation of check valve.	Replace if defective.
H. Control box malfunction.	See pages 40-41 for single phase.	Repair or replace.

Motor Runs But Overload Protector Trips

A. Incorrect voltage.	Using voltmeter, check the line terminals. Voltage must be within $\pm 10\%$ of rated voltage.	Contact power company if voltage is incorrect.
B. Overheated protectors.	Direct sunlight or other heat source can raise control box temperature causing protectors to trip. The box must not be hot to touch.	Shade box, provide ventilation or move box away from source.
C. Defective control box.	For detailed procedures, see pages 40-41.	Repair or replace.
D. Defective motor or cable.	For detailed procedures, see pages 38-40.	Repair or replace.
E. Worn pump or motor.	Check running current. See pages 13 & 21-23.	Replace pump and/or motor.



Maintenance - All Motors

Table 38 Preliminary Tests - All Sizes Single and Three Phase

"Test"	Procedure	What it Means
Insulation Resistance	<ol style="list-style-type: none"> 1. Open master breaker and disconnect all leads from control box or pressure switch (QD type control, remove lid) to avoid electric shock hazard and damage to the meter. 2. Set the scale lever to R X 100K and set the ohmmeter on zero. 3. Connect one ohmmeter lead to any one of the motor leads and the other lead to the metal drop pipe. If the drop pipe is plastic, connect the ohmmeter lead to ground. 	<ol style="list-style-type: none"> 1. If the ohms value is normal (Table 39), the motor is not grounded and the cable insulation is not damaged. 2. If the ohms value is below normal, either the windings are grounded or the cable insulation is damaged. Check the cable at the well seal as the insulation is sometimes damaged by being pinched.
Winding Resistance	<ol style="list-style-type: none"> 1. Open master breaker and disconnect all leads from control box or pressure switch (QD type control, remove lid) to avoid electric shock hazard and damage to the meter. 2. Set the scale lever to R X 1 for values under 10 ohms. For values over 10 ohms, set the scale lever to R X 10. "Zero" the ohmmeter. 3. On 3-wire motors measure the resistance of yellow to black (Main winding) and yellow to red (Start winding). <p>On 2-wire motors measure the resistance from line to line.</p> <p>Three phase motors measure the resistance line to line for all three combinations.</p>	<ol style="list-style-type: none"> 1. If all ohms values are normal (Tables 13, 21, 22 & 23), the motor windings are neither shorted nor open, and the cable colors are correct 2. If any one value is less than normal, the motor is shorted. 3. If any one ohm value is greater than normal, the winding or the cable is open, or there is a poor cable joint or connection. 4. If some ohms values are greater than normal and some less on single phase motors, the leads are mixed. See Page 40 to verify cable colors.

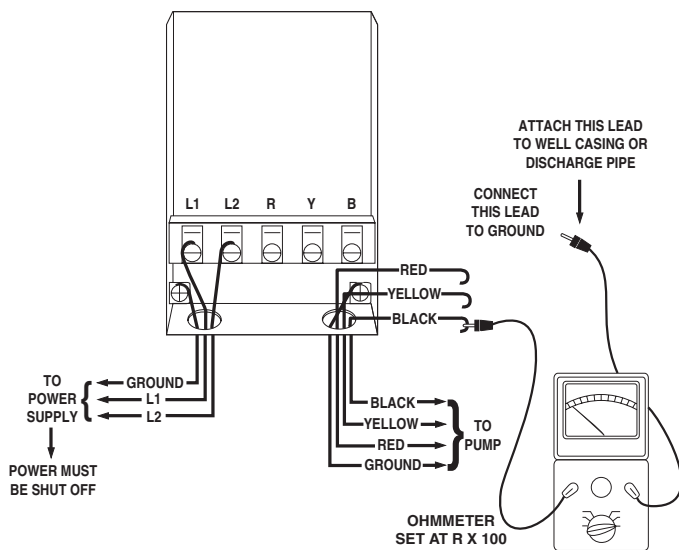

FIG. 13

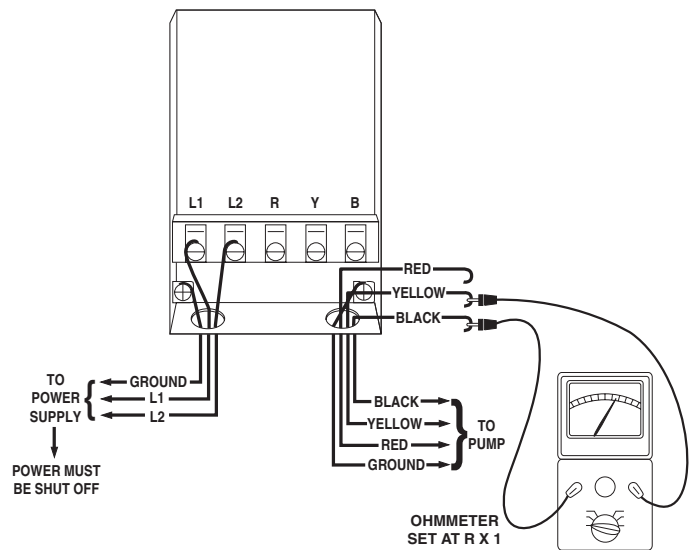

FIG. 14



Maintenance - All Motors

Insulation Resistance Readings

Table 39 Normal Ohm and Megohm Values Between All Leads and Ground

Condition of Motor and Leads	Ohm Value	Megohm Value
A new motor (without drop cable).	20,000,000 (or more)	20 (or more)
A used motor which can be reinstalled in well.	10,000,000 (or more)	10 (or more)
Motor in well. Readings are for drop cable plus motor.		
New motor.	2,000,000 (or more)	2 (or more)
Motor in good condition.	500,000 - 2,000,000	.5 - 2
Insulation damage, locate and repair.	Less than 500,000	Less than .5

Insulation resistance varies very little with rating. Motors of all HP, voltage, and phase ratings have similar values of insulation resistance.

Table 39 is based on readings taken with a megohmmeter with a 500V DC output. Readings may vary using a lower voltage ohmmeter, consult Franklin Electric if readings are in question.

Resistance of Drop Cable (Ohms)

The values below are for copper conductors. If aluminum conductor drop cable is used, the resistance will be higher. To determine the actual resistance of the aluminum drop cable, divide the ohm readings from this chart by 0.61. This chart shows total resistance of cable from control to motor and back.

Winding Resistance Measuring

When measured as shown in FIG 14, Page 38, motor resistance should fall within the values in Tables 13, 21, 22 & 23. When measured through the drop cable, the resistance of the drop cable as determined from the chart below, must be subtracted from the ohmmeter reading to get the winding resistance of the motor.

DC Resistance in Ohms per 100ft. of Wire (Two conductors) @ 50°F

AWG or MCM Wire Size (Copper)	14	12	10	8	6	4	3	2
Ohms	0.544	0.338	0.214	0.135	0.082	0.052	0.041	0.032

1	1/0	2/0	3/0	4/0	250 MCM	300 MCM	350 MCM	400 MCM	500 MCM	600 MCM	700 MCM
0.026	0.021	0.017	0.013	0.010	0.0088	0.0073	0.0063	0.0056	0.0044	0.0037	0.0032



Maintenance - Single Phase Motors & Controls

Identification Of Cables When Color Code Is Unknown (SINGLE PHASE 3-WIRE UNITS)

If the colors on the individual drop cables cannot be found with an ohmmeter, measure:

- Cable 1 to Cable 2
- Cable 2 to Cable 3
- Cable 3 to Cable 1

Find the highest resistance reading.

The lead not used in the highest reading is the yellow lead.

Use the yellow lead and each of the other two leads to get two readings:

- Highest is the red lead.
- Lowest is the black lead.

EXAMPLE:

The ohmmeter readings were:

- Cable 1 to Cable 2—6 ohms
- Cable 2 to Cable 3—2 ohms
- Cable 3 to Cable 1—4 ohms

The lead not used in the highest reading (6 ohms) was Cable 3—Yellow

From the yellow lead, the highest reading (4 ohms) was To Cable 1—Red

From the yellow lead, the lowest reading (2 ohms) was To Cable 2—Black

Single Phase Control Boxes

Checking and Repairing Procedures (Power On)

WARNING : Power must be on for these tests. Do not touch any live parts.

A. VOLTAGE MEASUREMENTS

Step 1. Motor Off

1. Measure voltage at L1 and L2 of pressure switch or line contactor.
2. Voltage Reading: Should be $\pm 10\%$ of motor rating.

Step 2. Motor Running

1. Measure voltage at load side of pressure switch or line contactor with pump running.
2. Voltage Reading: Should remain the same except for slight dip on starting. Excessive voltage drop can be caused by loose connections, bad contacts, ground faults, or inadequate power supply.
3. Relay chatter is caused by low voltage or ground faults.

B. CURRENT (AMP) MEASUREMENTS

1. Measure current on all motor leads.

2. Amp Reading: Current in red lead should momentarily be high, then drop within one second to values on Page 13. This verifies relay or solid state relay operation. Current in black and yellow leads should not exceed values on Page 13.

3. Relay or switch failures will cause red lead current to remain high and overload tripping.
4. Open run capacitor(s) will cause amps to be higher than normal in the black and yellow motor leads and lower than normal in the red motor lead.
5. A bound pump will cause locked rotor amps and overloading tripping.
6. Low amps may be caused by pump running at shutoff, worn pump, or stripped splines.
7. Failed start capacitor or open switch/relay are indicated if the red lead current is not momentarily high at starting.

CAUTION : The tests in this manual for components such as capacitors, relays, and QD switches should be regarded as indicative and not as conclusive. For example, a capacitor may test good (not open, not shorted) but may have lost some of its capacitance and may no longer be able to perform its function.

To verify proper operation of QD switches or relays, refer to operational test procedure described above in Section B-2.



Maintenance - Single Phase Motors & Controls

Ohmmeter Tests

QD, Solid State Control Box (Power Off)

A. START CAPACITOR AND RUN CAPACITOR IF APPLICABLE (CRC)

1. Meter Setting: R x 1,000.
2. Connections: Capacitor terminals.
3. Correct meter reading: Pointer should swing toward zero, then back to infinity.

B. Q.D. (BLUE) RELAY

Step 1. Triac Test

1. Meter setting: R x 1,000.
2. Connections: Cap and B terminal.
3. Correct meter reading: Infinity for all models.

Step 2, Coil Test

1. Meter Setting: R x 1.
2. Connections: L1 and B.
3. Correct meter reading: Zero ohms for all models.

C. POTENTIAL (VOLTAGE) RELAY

Step 1. Coil Test

1. Meter setting: R x 1,000.

2. Connections: #2 & #5.
3. Correct meter readings: For 115 Volt Boxes
.7-1.8 (700 to 1,800 ohms).
For 230 Volt Boxes
4.5-7.0 (4,500 to 7,000 ohms).

Step 2. Contact Test

1. Meter setting: R x 1.
2. Connections: #1 & #2.
3. Correct meter reading: Zero for all models.

D. SOLID STATE SWITCH

Step 1. Triac Test

1. Meter Setting: R x 1,000.
2. Connections: R (Start) terminal and orange lead on start switch.
3. Correct meter reading: Infinity for all models.

Step 2. Coil Test

1. Meter Setting: R x 1.
2. Connections: Y (Common) and L2.
3. Correct meter reading: Zero ohms for all models.

Ohmmeter Tests

Integral Horsepower Control Box (Power Off)

A. OVERLOADS (Push Reset Buttons to make sure contacts are closed.)

1. Meter Setting: R x 1.
2. Connections: Overload terminals.
3. Correct meter reading: Less than 0.5 ohms.

B. CAPACITOR (Disconnect leads from one side of each capacitor before checking.)

1. Meter Setting: R x 1,000.
2. Connections: Capacitor terminals.
3. Correct meter reading: Pointer should swing toward zero, then drift back to infinity, except for capacitors with resistors which will drift back to 15,000 ohms.

C. RELAY COIL (Disconnect lead from Terminal #5)

1. Meter Setting: R x 1,000.
2. Connections: #2 & #5.
3. Correct meter readings: 4.5-7.0 (4,500 to 7,000 ohms) for all models.

D. RELAY CONTACT (Disconnect lead from Terminal #1)

1. Meter Setting: R x 1.
2. Connections: #1 & #2.
3. Correct meter reading: Zero ohms for all models.

E. CONTACTOR COIL (Disconnect lead from one side of coil)

1. Meter Setting: R x 100.
2. Connections: Coil terminals.
3. Correct meter reading: 180 to 1,400 ohms.

F. CONTACTOR CONTACTS

1. Meter Setting: R X 1.
2. Connections: L1 & T1 or L2 & T2.
3. Manually close contacts.
4. Correct meter reading: Zero ohms.

CAUTION : The tests in this manual for components such as capacitors, relays, and QD switches should be regarded as indicative and not as conclusive. For example, a capacitor may test good (not open, not shorted) but may have lost some of its capacitance and may no longer be able to perform its function.

To verify proper operation of QD switches or relays, refer to operational test procedure described on Page 40, Section B-2.



Maintenance - Single Phase Motors & Controls

Table 42 QD Control Box Parts 60 Hz

HP	Volts	Control Box Model Number	QD (Blue) Relay	Start Capacitor	MFD	Volts	Run Capacitor	MFD	Volts
1/3	115	2801024915	223415905	275464125	159-191	110			
	230	2801034915	223415901	275464126	43-53	220			
1/2	115	2801044915	223415906	275464201	250-300	125			
	230	2801054915	223415902	275464105	59-71	220			
	230	2824055015 (CRC)	223415912	275464126	43-53	220	156132101	15	370
3/4	230	2801074915	223415903	275464118	86-103	220			
	230	2824075015 (CRC)	223415913	275464105	59-71	220	156132102	23	370
1	230	2801084915	223415904	275464113	105-126	220			
	230	2824085015 (CRC)	223415914	275464118	86-103	220	156132102	23	370

NOTE 1: Control boxes supplied with QD relays are designed to operate on 230 volt systems. For 208 volt systems or where line voltage is between 200 volts and 210 volts use the next larger cable size, or use a boost transformer to raise the voltage.

NOTE 2: Voltage relays kits for 115 volts (305102 901) and 230 volts (305102 902) will replace current, voltage or QD relays, and solid state switches.

QD Capacitor Replacement Kits

Capacitor Number	Kit
275 464 105	305 207 905
275 464 113	305 207 913
275 464 118	305 207 918
275 464 125	305 207 925
275 464 126	305 207 926
156 132 101	305 203 907
156 132 102	305 203 908

QD Overload Kits 60 Hz

HP	Volts	Kit (1)
1/3	115	305100 901
1/3	230	305100 902
1/2	115	305100 903
1/2	230	305100 904
3/4	230	305100 905
1	230	305100 906

(1) For Control Boxes with model numbers that end with 915.

QD Relay Replacement Kits

QD Relay Number	Kit
223 415 901	305 101 901
223 415 902	305 101 902
223 415 903	305 101 903
223 415 904	305 101 904
223 415 905	305 101 905
223 415 906	305 101 906
223 415 912 (CRC)	305 105 901
223 415 913 (CRC)	305 105 902
223 415 914 (CRC)	305 105 903



Maintenance - Single Phase Motors & Controls

Table 43 Integral Horsepower Control Box Parts 60 Hz

Motor Size	Motor Rating HP	Control Box (1) Model No.	Capacitors				Overload (2) Part No.	Relay (3) Part No.	Contactor (2) Part No.
			Part No. (2)	Mfd.	Volts	Qty.			
4"	1 1/2 Standard	282 3008 110	275 464 113 S	105-126	220	1	275 411 107	155 031 102	
			155 328 102 R	10	370	1			
4"	2 Standard	282 3018 110	275 464 113 S	105-126	220	1	275 411 107 S	155 031 102	
			155 328 103 R	20	370	1	275 411 113 M		
4"	2 Deluxe	282 3018 310	275 464 113 S	105-126	220	1	275 411 107 S	155 031 102	155 325 102 L
			155 328 103 R	20	370	1	275 411 113 M		
4"	3 Standard	282 3028 110	275 463 111 S	208-250	220	1	275 411 108 S	155 031 102	
			155 327 102 R	35	370	1	275 411 115 M		
4"	3 Deluxe	282 3028 310	275 463 111 S	208-250	220	1	275 411 108 S	155 031 102	155 325 102 L
			155 327 102 R	35	370	1	275 411 115 M		
4" & 6"	5 Standard	282 1138 110	275 468 119 S	270-324	330	1	275 411 102 S	155 031 102	
			155 327 101 R	30	370	2	275 406 102 M		
4" & 6"	5 Deluxe	282 1138 310 or	275 468 119 S	270-324	330	1	275 411 102 S	155 031 102	155 326 101 L
		282 1139 310	155 327 101 R	30	370	2	275 406 102 M		
6"	7 1/2 Standard	282 2019 210	275 468 119 S	270-324	330	1	275 411 102 S	155 031 601	
			275 468 118 S	216-259	330	1	275 406 122 M		
			155 327 109 R	45	370	1			
6"	7 1/2 Deluxe	282 2019 310	275 468 119 S	270-324	330	1	275 411 102 S	155 031 601	155 326 101 L
			275 468 118 S	216-259	330	1	275 406 121 M		
			155 327 109 R	45	370	1			
6"	10 Standard	282 2029 210	275 468 119 S	270-324	330	1	275 406 103 S	155 031 601	
			275468 120 S	350-420	330	1			
			155 327 102 R	35	370	2	155 409 101 M		
6"	10 Deluxe	282 2029 310	275 468 119 S	270-324	330	1	275 406 103 S	155 031 601	155 326 102 L
			275468 120 S	350-420	330	1			
			155 327 102 R	35	370	2	155 409 101 M		
6"	15 Deluxe	282 2039 310	275 468 120 S	350-420	330	2	275 406 103 S	155 031 601	155 429 102 L
			155 327 109 R	45	370	3	155 409 102 M		

FOOTNOTES:

- (1) Lightning arrestors 150 814 902 are suitable for all control boxes.
- (2) S = Start, M = Main, L = Line, Deluxe = Control box with line contactors
- (3) For 208V systems or where line voltage is between 200V and 210V a low voltage relay is required. Use relay part 155 031 601 in place of 155 031 102 or 155 031 602 in place of 155 031 601. Use the next larger cable size than specified in 230V table. Boost transformers per Page 14 are an alternative to special relays and cable.



Maintenance - Single Phase Motors & Controls

Integral HP Capacitor Replacement Kits

Capacitor Number	Kit
275 463 111	305 206 911
275 464 113	305 207 913
275 468 117	305 208 917
275 468 118	305 208 918
275 468 119	305 208 919
155 327 101	305 203 901
155 327 102	305 203 902
155 327 109	305 203 909
155 328 102	305 204 902
155 328 103	305 204 903

Integral HP Overload Replacement Kits

Overload Number	Kit
275 406 102	305 214 902
275 406 103	305 214 903
275 406 121	305 214 921
275 406 122	305 214 922
275 411 102	305 215 902
275 411 107	305 215 907
275 411 108	305 215 908
275 411 113	305 215 913
275 411 115	305 215 915

Integral HP Voltage Relay Replacement Kits

Relay Number	Kit
155 031 102	305 213 902
155 031 601	305 213 961



Maintenance - Single Phase Motors & Controls

Control Box Wiring Diagrams

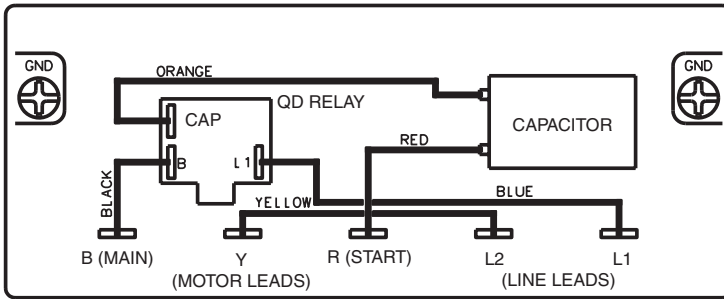

1/3 - 1 HP QD RELAY
 280 10_ 4915
 Sixth digit depends on HP

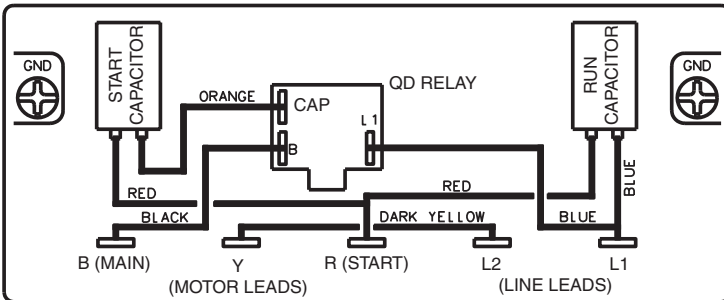

1/2 - 1 HP CRC QD RELAY
 282 40_ 5015
 Sixth digit depends on HP

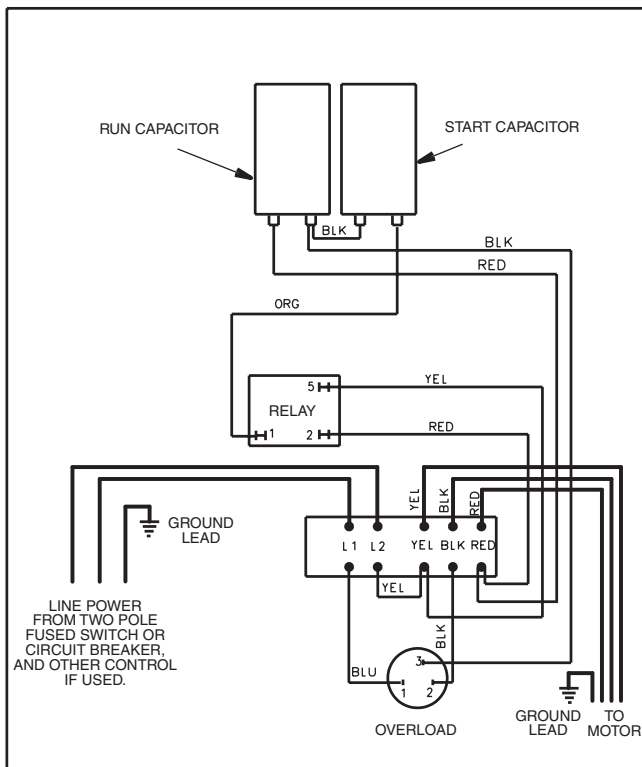

1 1/2 HP
 282 300 8110



Maintenance - Single Phase Motors & Controls

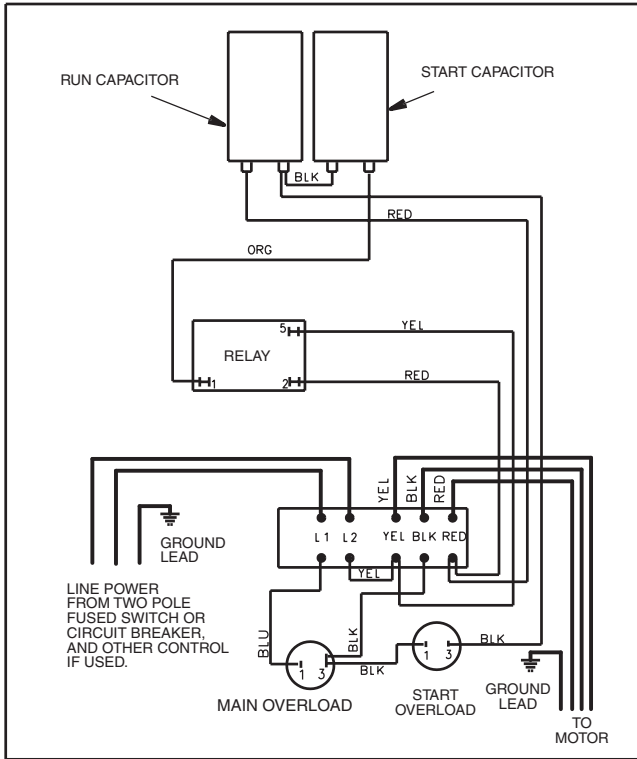

2 HP STANDARD
282 301 8110

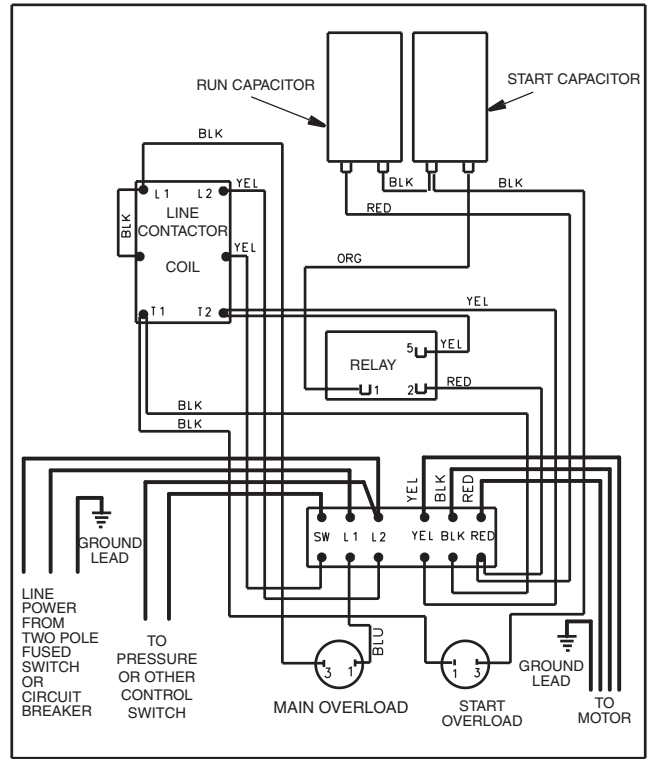

2 HP DELUXE
282 301 8310

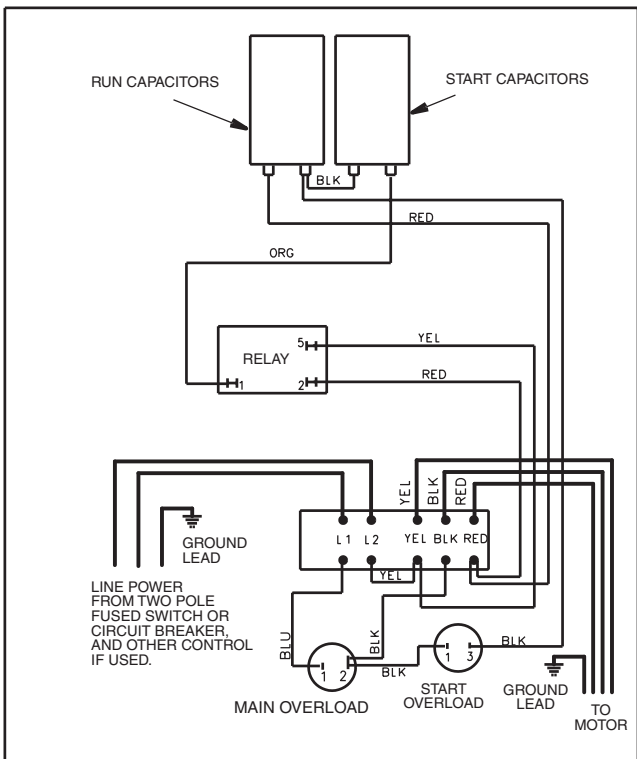

3 HP STANDARD
282 302 8110

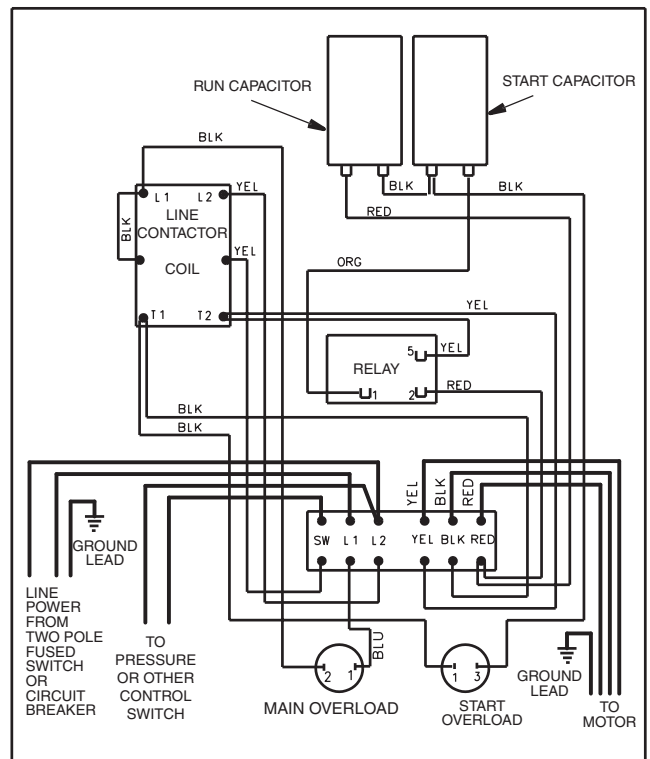

3 HP DELUXE
282 302 8310



Maintenance - Single Phase Motors & Controls

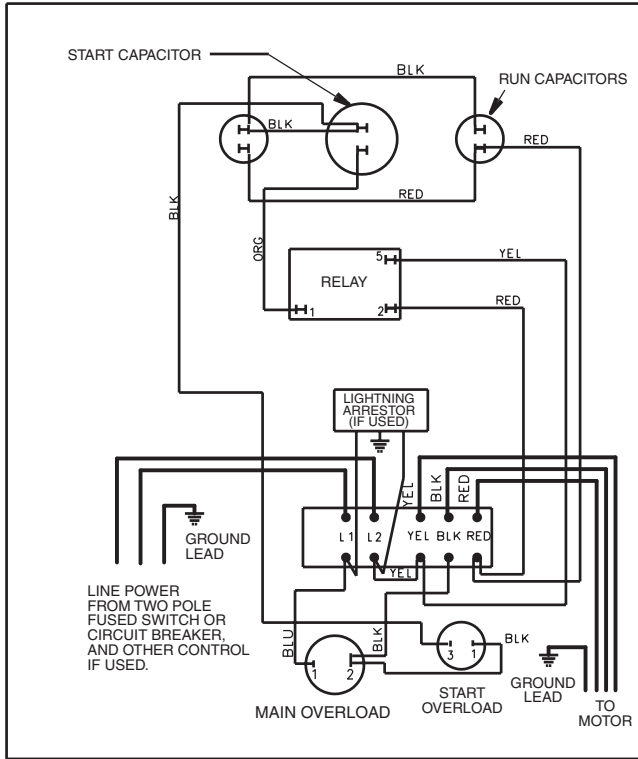

5 HP STANDARD
282 113 8110

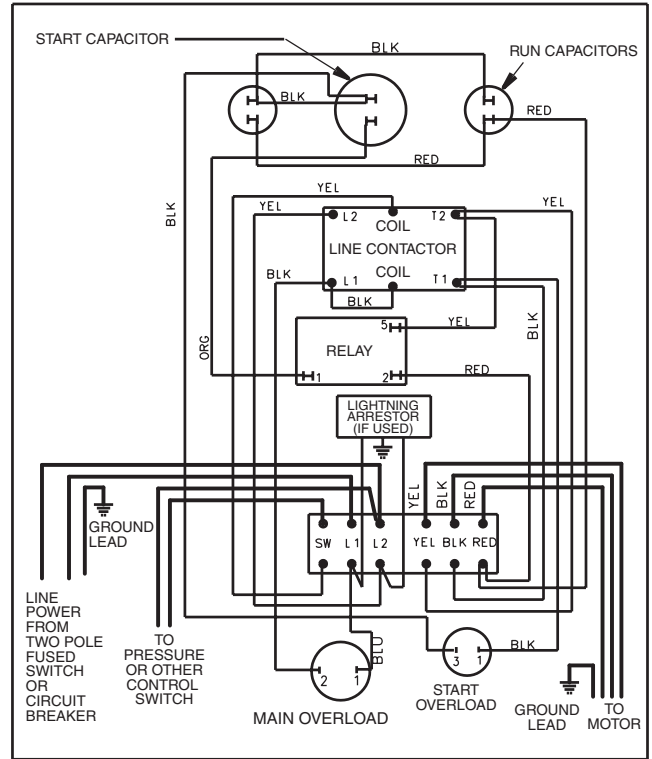

5 HP DELUXE
282 113 8310 or 282 113 9310

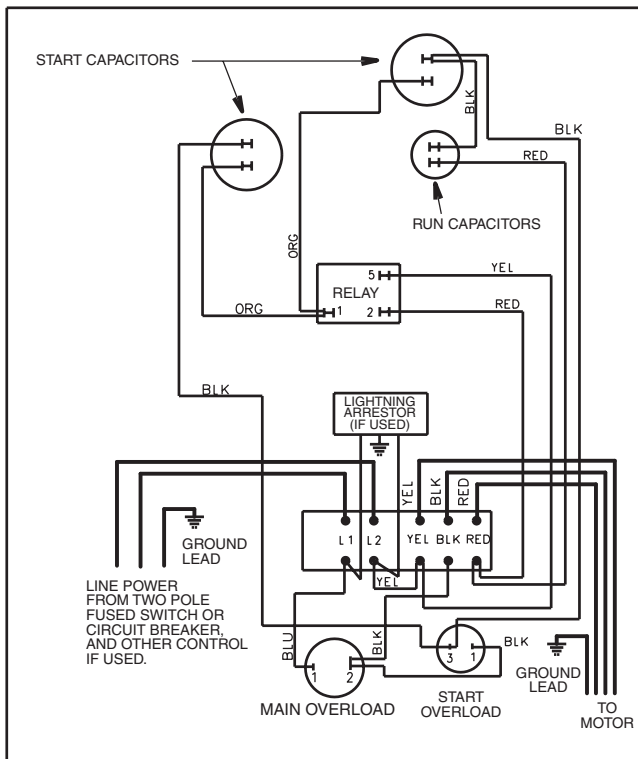

7½ HP STANDARD
282 201 9210

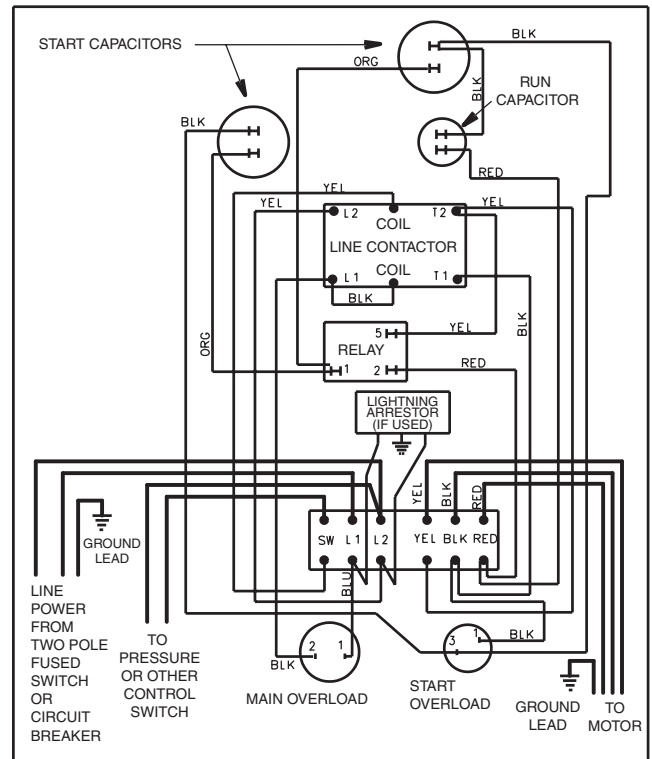

7½ HP DELUXE
282 201 9310



Maintenance - Single Phase Motors & Controls

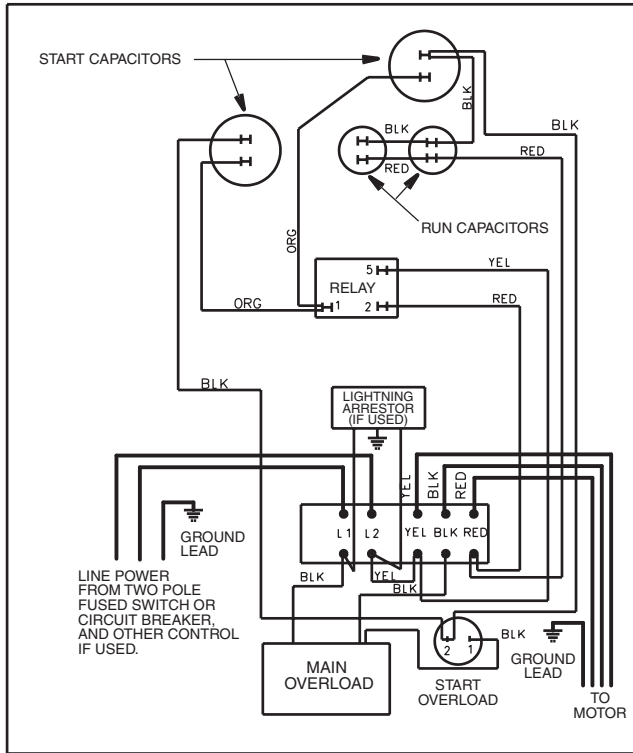

10 HP STANDARD
282 202 9210

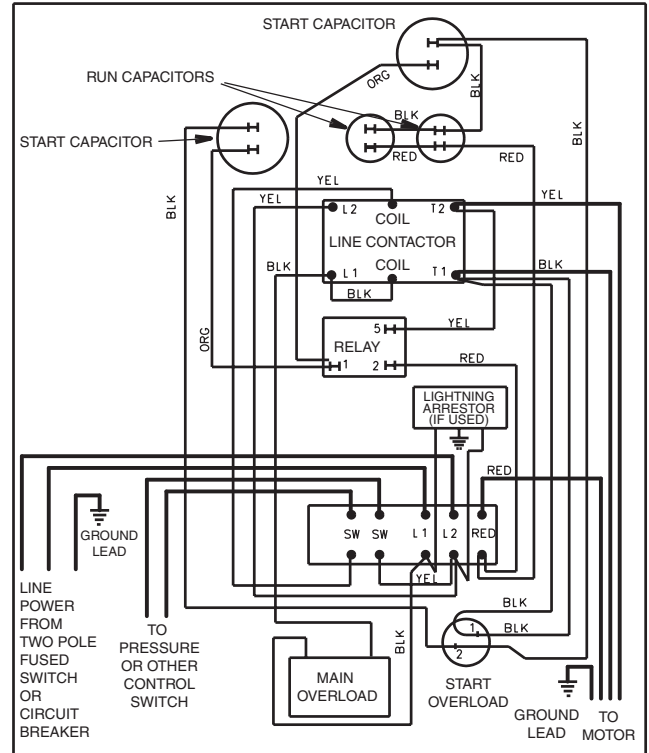

10 HP DELUXE
282 202 9310

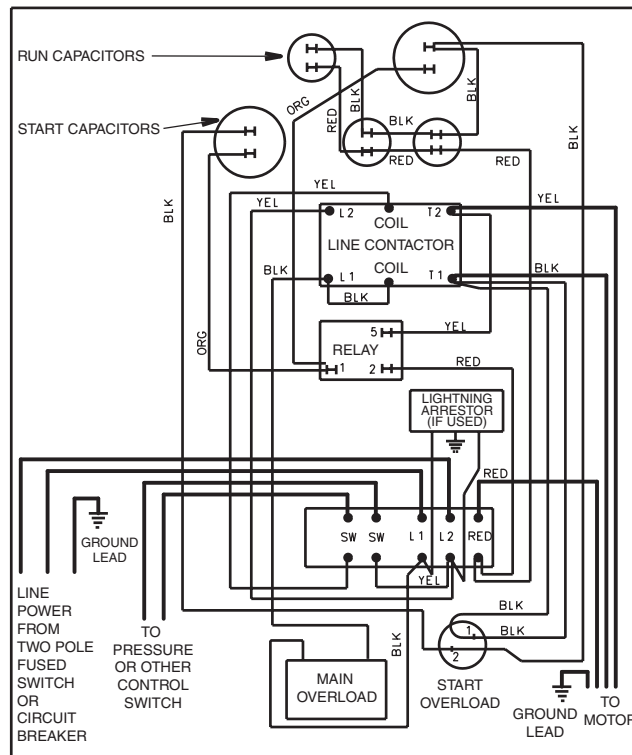

15 HP DELUXE
282 203 9310



Maintenance - Electronic Products

Pumptec-Plus

Pumptec-Plus is a pump/motor protection device designed to work on any 230V single phase induction motor (PSC, CSCR, CSIR, and split phase) ranging in size from 1/2 to 5 horsepower. Pumptec-Plus uses a micro-computer to continuously monitor motor power and line voltage to provide protection against dry well, water logged tank, high and low voltage and mud or sand clogging.

Pumptec-Plus - Trouble Shooting During Installation

Symptom	Possible Cause	Solution
Unit Appears Dead (No Lights)	No Power to Unit	Check wiring. Power supply voltage should be applied to L1 and L2 terminals of the Pumptec-Plus. In some installations the pressure switch or other control device is wired to the input of the Pumptec-Plus. Make sure this switch is closed.
Flashing Yellow Light	Unit Needs To Be Calibrated	Pumptec-Plus is calibrated at the factory so that it will overload on most pump systems when the unit is first installed. This overload condition is a reminder that the Pumptec-Plus unit requires calibration before use. See step 7 of the installation instructions.
	Miscalibrated	Pumptec-Plus should be calibrated on a full recovery well with the maximum water flow. Flow restrictors are not recommended.
Flashing Yellow Light During Calibration	Two-Wire Motor	Step C of the calibration instructions indicate that a flashing green light condition will occur 2 to 3 seconds after taking the SNAPSHOT of the motor load. On some two-wire motors the yellow light will flash instead of the green light. Press and release the reset button. The green should start flashing.
Flashing Red and Yellow Lights	Power Interruption	During the installation of Pumptec-Plus power may be switched on and off several times. If power is cycled more than four times within a minute Pumptec-Plus will trip on rapid cycle. Press and release the reset button to restart the unit.
	Float Switch	A bobbing float switch may cause the unit to detect a rapid cycle condition on any motor or an overload condition on two wire motors. Try to reduce water splashing or use a different switch.
Flashing Red Light	High Line Voltage	The line voltage is over 253 volts. Check line voltage. Report high line voltage to the power company.
	Unloaded Generator	If you are using a generator the line voltage may become too high when the generator unloads. Pumptec-Plus will not allow the motor to turn on again until the line voltage returns to normal. Over voltage trips will also occur if line frequency drops too far below 60 Hz.
Solid Red Light	Low Line Voltage	The line voltage is below 207 volts. Check line voltage.
	Loose Connections	Check for loose connections which may cause voltage drops.
	Loaded Generator	If you are using a generator the line voltage may become too low when the generator loads. Pumptec-Plus will trip on undervoltage if the generator voltage drops below 207 volts for more than 2.5 seconds. Undervoltage trips will also occur if the line frequency rises too far above 60 Hz.



Maintenance - Electronic Products

Pumptec-Plus

Pumptec-Plus - Trouble Shooting After Installation

Symptom	Possible Cause	Solution
Solid Yellow Light	Dry Well	Wait for the automatic restart timer to time out. During the time out period, the well should recover and fill with water. If the automatic reset timer is set to the manual position, then the reset button must be pressed to reactivate the unit.
	Blocked Intake	Clear or replace pump intake screen.
	Blocked Discharge	Remove blockage in plumbing.
	Check Valve Stuck	Replace check valve.
	Broken Shaft	Replace broken parts.
	Severe Rapid Cycling	Machine gun rapid cycling can cause an underload condition. See flashing red and yellow lights section below.
	Worn Pump	Replace worn pump parts and recalibrate.
Yellow Flashing Light	Stalled Motor	Repair or replace motor. Pump may be sand or mud locked.
	Float Switch	A bobbing float switch can cause two-wire motors to stall. Arrange plumbing to avoid splashing water. Replace float switch.
	Ground Fault	Check insulation resistance on motor and control box cable.
Solid Red Light	Low Line Voltage	The line voltage is below 207 volts. Pumptec-Plus will try to restart the motor every two minutes until line voltage is normal.
	Loose Connections	Check for excessive voltage drops in the system electrical connections (i.e. circuit breakers, fuse clips, pressure switch, and Pumptec-Plus L1 and L2 terminals). Repair Connections.
Flashing Red Light	High Line Voltage	The line voltage is over 253 volts. Check line voltage. Report high line voltage to the power company.
Flashing Red and Yellow Lights	Rapid Cycle	The most common cause for the rapid cycle condition is a waterlogged tank. Check for a ruptured bladder in the water tank. Check the air volume control or snifter valve for proper operation. Check setting on the pressure switch and examine for defects.
	Leaky Well System	Replace damaged pipes or repair leaks.
	Stuck Check Valve	Failed valve will not hold pressure. Replace Valve.
	Float Switch	Press and release the reset button to restart the unit. A bobbing float switch may cause the unit to detect a rapid cycle condition on any motor or an overload condition on two wire motors. Try to reduce water splashing or use a different switch.



Maintenance - Electronic Products

CP Water System

The Franklin Electric CP (Constant Pressure) Water System is a variable-speed water system that utilizes a variable-speed drive system to deliver water at a constant pressure.

WARNING:

Serious or fatal electrical shock may result from failure to connect the motor, CP Water Controller, metal plumbing and all other metal near the motor or cable to the power supply ground terminal using wire no smaller than motor cable wires. To reduce the risk of electrical shock, disconnect power before working on or around the water system. Capacitors inside the CP Water Controller can still hold a lethal voltage even after power has been removed. Allow 10 minutes for dangerous internal voltage to discharge. Do not use motor in swimming areas.

CP Water System Troubleshooting

Should an application or system problem occur, a built-in diagnostics will protect the system. The "FAULT" light on the front of the CP Water Controller will flash a given number of times indicating the nature of the fault. In some cases, the system will shut itself off until corrective action is taken. Fault codes and their corrective actions are listed below.

# of Flashes	Fault	Possible Cause	Corrective Action
1	Motor underload	Overpumped or dry well. Worn pump. Broken motor shaft. Blocked pump screen.	Wait for well to recover and automatic restart timer to time out. If the problem does not correct, check motor and pump. See description of "smart reset" in CP Water installation manual.
2	Undervoltage	Low line voltage.	Check for loose connections. Check line voltage. Report low voltage to the power company. Unit will start automatically when proper power is supplied.
3	Locked pump	Motor/pump misaligned. Sand bound pump.	Cycle input power*. On power up, unit will attempt to free a locked pump. If unsuccessful, check the motor and pump.
4	Rapid cycling (unit still runs)	Waterlogged tank.	With no water pressure, check air pressure in tank. Pressure should be 10-15 PSI below CP Water pressure setting.
5	Open circuit	Loose connections. Defective motor or cable.	Check motor wiring. Make certain all connections are tight. Make certain proper motor is installed. Cycle input power* to reset.
6	Short circuit	Defective motor or cable.	Check motor wiring.
7	Overheat	High ambient temperature. Direct sunlight. No water flow through the unit.	This fault automatically resets when temperature returns to a safe level.
8	Internal sensor fault		Cycle input power*. If problem persists, replace CP Water Controller.

*"Cycle input power" means turn the power off for 5 seconds and then back on again.



Maintenance - Electronic Products

QD Pumptec and Pumptec

QD Pumptec and Pumptec are load sensing devices that monitor the load on submersible pump/motors. If the load drops below a preset level for a minimum of 4 seconds the QD Pumptec or the Pumptec will shut off the motor.

The QD Pumptec is designed and calibrated expressly for use on Franklin Electric 230V 3-wire motors (1/3 to 1HP). The QD Pumptec must be installed in QD relay boxes.

The Pumptec is designed for use on Franklin Electric 2- and 3-wire motors (1/3 to 1 1/2 HP) 115 and 230V. The Pumptec is not designed for Jet Pumps.

QD Pumptec & Pumptec -Trouble Shooting

Symptom	Checks or Solution
QD Pumptec or Pumptec trips in about 4 seconds with some water delivery.	<ul style="list-style-type: none"> A. Is the voltage more than 90% of nameplate rating? B. Are the pump and motor correctly matched? C. Is the QD Pumptec or Pumptec wired correctly? For the Pumptec check the wiring diagram and pay special attention to the positioning of the power lead (230V or 115V). For QD Pumptec is your system 230V 60 Hz or 220V 50 Hz?
QD Pumptec or Pumptec trips in about 4 seconds with no water delivery.	<ul style="list-style-type: none"> A. The pump may be airlocked. If there is a check valve on top of the pump, put another section of pipe between the pump and the check valve. B. The pump may be out of water. C. Check the valve settings. The pump may be dead-heading. D. Pump or motor shaft may be broken. E. Motor overload may be tripped. Check the motor current (amperage).
QD Pumptec or Pumptec will not time out and reset.	<ul style="list-style-type: none"> A. Check switch position on side of circuit board on Pumptec. QD Pumptec check timer position on top/front of unit. Make sure the switch is not between settings. B. If the reset time switch is set to manual reset (position 0), QD Pumptec and Pumptec will not reset (turn power off for 5 sec. then back on to reset).
The pump/motor will not run at all.	<ul style="list-style-type: none"> A. Check voltage. B. Check wiring. C. Remove the QD Pumptec from the control box. Reconnect wires in box to original state. If motor does not run the problem is not QD Pumptec. Bypass Pumptec by connecting L2 and motor lead with jumper. Motor should run. If not, the problem is not Pumptec. D. On Pumptec only, check that Pumptec is installed between the control switch and the motor.
QD Pumptec or Pumptec will not trip when the pump breaks suction.	<ul style="list-style-type: none"> A. Be sure you have a Franklin motor. B. Check wiring connections. On Pumptec is lead power (230V or 115V) connected to correct terminal? Is motor lead connected to correct terminal? C. Check for ground fault in the motor and excessive friction in the pump. D. The well may be "gulping" enough water to keep QD Pumptec or Pumptec from tripping. It may be necessary to adjust the QD Pumptec or the Pumptec for these extreme applications. Call the Franklin Electric Service Hotline at 800-348-2420 for information. E. On Pumptec applications does the control box have a run capacitor? If so, Pumptec will not trip. (Except for Franklin 1 1/2 HP motors)
QD Pumptec or Pumptec chatters when running.	<ul style="list-style-type: none"> A. Check for low voltage. B. Check for waterlogged tank. Rapid cycling for any reason can cause the QD Pumptec or the Pumptec relay to chatter. C. On Pumptec make sure the L2 and motor wires are installed correctly. If they are reversed, the unit can chatter.



Maintenance - Electronic Products

Subtrol-Plus

Subtrol-Plus - Trouble Shooting After Installation

Symptom	Possible Cause or Solution
Subtrol-Plus Dead	When the Subtrol-Plus reset button is depressed and released, all indicator lights should flash. If line voltage is correct at the Subtrol-Plus and the L1, L2, L3 terminals, and the reset button does not cause lights to flash, Subtrol-Plus receiver is malfunctioning.
Green Off Time Light Flashes	The green light will flash and not allow operation unless both sensor coils are plugged into the receiver. If both are properly connected and it still flashes, the sensor coil or the receiver is faulty. An ohmmeter check between the two center terminals of each sensor coil connected should read less than 1 ohm, or coil is faulty. If both coils check good, receiver is faulty.
Green Off Time Light On	The green light is on and the Subtrol-Plus requires the specified off time before the pump can be restarted after having been turned off. If the green light is on except as described, the receiver is faulty. Note that a power interruption when the motor is running will initiate the delay function.
Overheat Light On	This is a normal protective function which turns off the pump when the motor reaches maximum safe temperatures. Check that amps are within the nameplate maximum on all three lines, and that the motor has proper water flow past it. If overheat trip occurs without apparent motor overheating, it may be the result of an arcing connection somewhere in the circuit or extreme noise interference on the power lines. Check with the power company or Franklin Electric. A true motor overheat trip will require at least five minutes for a motor started cold. If trips do not conform to this characteristic, suspect arcing connections, power line noise, ground fault, or SCR variable speed control equipment.
Overload Light On	This is a normal protective function, protecting against an overload or locked pump. Check the amps in all lines through a complete pumping cycle, and monitor whether low or unbalanced voltage may be causing high amps at particular times. If overload trip occurs without high amps, it may be caused by a faulty rating insert, receiver, or sensor coil. Recheck that the insert rating matches the motor. If it is correct, carefully remove it from the receiver by alternately lifting sides with a knife blade or thin screwdriver, and make sure it has no pins bent over. If the insert is correct and its pins are okay, replace receiver and/or sensor coils.
Underload Light On	This is a normal protective function. <ol style="list-style-type: none"> A. Make sure the rating insert is the correct for the motor. B. Adjusting the underload setting as described to allow the desired range of operating conditions. Note that a DECREASE in underload setting is required to allow loading without trip. C. Check for drop in amps and delivery just before trip, indicating pump breaking suction, and for unbalanced line current. D. With the power turned off, recheck motor lead resistance to ground. A grounded lead can cause underload trip.



Maintenance - Electronic Products

Subtrol-Plus

Subtrol-Plus - Trouble Shooting After Installation (Continued)

Symptom	Possible Cause or Solution
Tripped Light On	Whenever the pump is off as a result of Subtrol-Plus protective function, the red tripped light is on. A steady light indicates the Subtrol-Plus will automatically allow the pump to restart as described, and a flashing light indicates repeated trips, requiring manual reset before the pump can be restarted. Any other red light operation indicates a faulty receiver. One-half voltage on 460V will cause tripped light on.
Control Circuit Fuse Blows	With power turned off, check for a shorted contactor coil or a grounded control circuit lead. The coil resistance should be at least 10 ohms and the circuit resistance to panel frame over 1 megohm. A standard or delay-type 2 amp fuse should be used.
Contactor Will Not Close	<p>If proper voltage is at the control coil terminals when controls are operated to turn the pump on, but the contactor does not close, turn off power and replace the coil. If there is no voltage at the coil, trace the control circuit to determine if the fault is in the Subtrol-Plus receiver, fuse, wiring, or panel operating switches. This tracing can be done by first connecting a voltmeter at the coil terminals, and then moving the meter connections step by step along each circuit to the power source, to determine at which component the voltage is lost.</p> <p>With the Subtrol-Plus receiver powered up, with all leads disconnected from the control terminals and with an ohmmeter set at R X 10, measure the resistance between the control terminals. It should measure 100 to 400 ohms. Depress and hold in the reset button. The resistance between the control terminals should measure close to infinity.</p>
Contactor Hums or Chatters	Check that coil voltage is within 10% of rated voltage. If voltage is correct and matches line voltage, turn off power and remove the contactor magnetic assembly and check for wear, corrosion, and dirt. If voltage is erratic or lower than line voltage trace the control circuit for faults similar to the previous item, but looking for a major drop in voltage rather than its complete loss.
Contactor Opens When Start Switch is Released	Check that the small interlocks switch on the side of the contactor closes when the contactor closes. If the switch or circuit is open, the contactor will not stay closed when the selector switch is in HAND position.
Contactor Closes But Motor Doesn't Run	Turn off power. Check the contactor contacts for dirt, corrosion, and proper closing when the contactor is closed by hand.
Signal Circuit Terminals Do Not Energize	With the Subtrol-Plus receiver powered up and all leads disconnected from the Signal terminals, with an ohmmeter set at R X 10, measure the resistance between the Signal terminals. Resistance should measure close to infinite. Depress and hold in the reset button, the resistance between the signal terminals should measure 100 to 400 ohms.



Notes



Notes



Notes

TOLL FREE HELP FROM A FRIEND

1-800-348-2420

1-219-827-5102 FAX

Phone Franklin's toll free SERVICE HOTLINE for answers to your installation questions on submersible pump motors. When you call, a Franklin expert will offer assistance in troubleshooting submersible systems and provide immediate answers to your motor application questions. Technical support is also available online. Visit our website at:

www.franklin-electric.com



Franklin Electric

Bluffton, Indiana 46714